

A GLOBAL LEADER IN METAL FLOW ENGINEERING

**Capital Markets Day**  
**Delivering on our Commitments**

Düsseldorf, Germany | 18 – 19 June 2015

**VESUVIUS** PLC

# Disclaimer

This presentation, which has been prepared by Vesuvius plc (the "Company"), includes statements that are, or may be deemed to be, "forward looking statements". These forward looking statements can be identified by the use of forward looking terminology, including the terms "believes", "estimates", "plans", "projects", "anticipates", "expects", "intends", "may", "will", or "should" or, in each case, their negative or other variations or comparable terminology. These forward looking statements include matters that are not historical facts and include statements regarding the Company's intentions, beliefs or current expectations. By their nature, forward looking statements involve risk and uncertainty because they relate to future events and circumstances. A number of factors could cause actual results and developments to differ materially from those expressed or implied by any forward looking statements. Any forward looking statements in this presentation reflect the Company's view with respect to future events as at the date of this presentation and are subject to risks relating to future events and other risks, uncertainties and assumptions relating to the Company's operations, results of operations, growth strategy and liquidity. The Company undertakes no obligation publicly to release the results of any revisions or updates to any forward looking statements in this presentation that may occur due to any change in its expectations or to reflect events or circumstances after the date of this presentation.

This presentation comprises information which is already in the public domain, and includes extracts from the Announcement of the Results for the year ended 31 December 2014 (3 Mar 2015). You should read the whole of that Results Announcement. No reliance should be placed for any purposes whatsoever on the information contained in this document or on its completeness. None of the Company, its advisers, or any other party is under any duty to update or inform you of any changes to the information contained in this presentation other than in compliance with ongoing regulatory obligations.

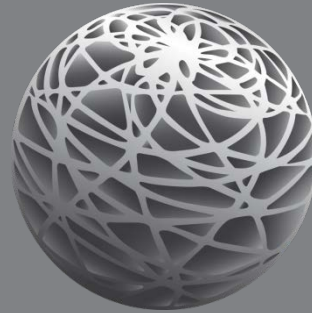

A GLOBAL LEADER IN METAL FLOW ENGINEERING

## Markets perspectives and strategy

François Wanecq  
Chief Executive

VESUVIUS PLC

# An experienced international management team...

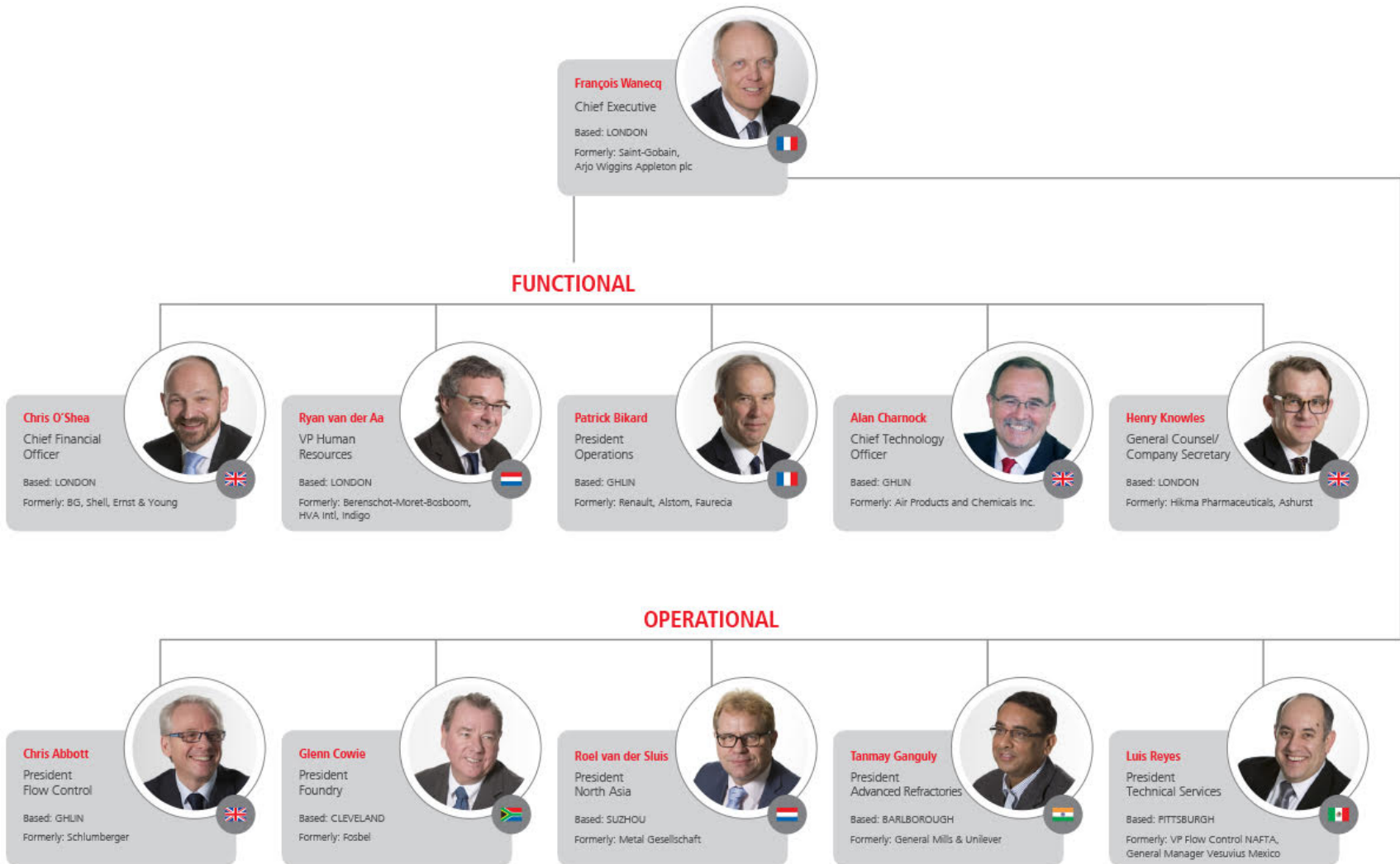

# ... supported by a strong Board



**John McDonough**  
CBE  
Chairman

John joined Vesuvius as Chairman in 2012. CEO of Carillion plc for 11 years until his retirement in 2011, John has been the Chairman of The Vitec Group plc since June 2012. John was formerly a Non Executive Director of Exel plc, and Chair of the Remuneration Committee of Tomkins plc from 2007 to 2010.



**Douglas Hurt**  
Senior Independent  
Director and  
Audit Committee  
Chair

Douglas joined Vesuvius in 2015 as a Non Executive Director. A Chartered Accountant, Douglas also has significant financial experience as Finance Director of IMI plc and has held numerous senior finance positions at GlaxoSmithKline plc. He chairs the Audit Committee and is a Non Executive Director at Tate & Lyle plc.



**Jane Hinkley**  
Non Executive  
Director and  
Remuneration  
Committee Chair

Jane joined Vesuvius in 2012 as a Non Executive Director. Jane has significant international experience as Managing Director of Navion Shipping AS and CFO then CEO of Gotaas-Larsen Shipping Corp. Jane chairs the remuneration committee at Premier Oil plc and is a Non Executive Director of Teekay GP LLC.



**Christer Gardell**  
Non Executive  
Director

Christer joined the Cookson Group plc Board in 2012. He is Managing Partner of Cevian Capital, which holds over 20% of Cookson Group plc's issued share capital, and a Non Executive Director of Metso Corporation. Previously a Non Executive Director of AB Lindex and Tieto Corporation.



**Nelda Connors**  
Non Executive  
Director

Nelda joined Vesuvius in 2013 as a Non Executive Director. Nelda was President and CEO of Tyco International, Electrical & Metals Products. Nelda is a Non Executive Director of Blount International, Inc. and Boston Scientific Corporation and sits on the Board of the Federal Reserve Bank of Chicago and is Chairwoman and Founder of Pine Grove Holdings, LLC.



**Hock Goh**  
Non Executive  
Director

Hock joined Vesuvius in 2015 as a Non Executive Director. Hock has more than 30 years' experience in the oil and gas industry. Hock is Chairman of MEC Resources Ltd and Advent Energy Ltd, and is a Non Executive Director of AB SKF, BPH Energy Ltd, Santos Ltd, Stora Enso Oyj, and KS Distribution Pte Ltd.



**François Wanecq**  
Chief Executive

François joined Cookson Group plc in 2005 as CEO of the Engineered Ceramics division, and joined the Board in 2010. Previously chief executive of ArjoWiggins, and head of technical ceramics division at Saint-Gobain from 1985 to 1995. He graduated at Ecole Polytechnique and Ecole des Mines in Paris.



**Chris O'Shea**  
Chief Financial  
Officer

Chris joined Vesuvius in 2012 as CFO. He was previously with BG Group where he was CFO Africa, Middle East & Asia, and prior to that spent 8 years with Shell in the UK, the US and Africa. A Chartered Accountant, Chris has an MBA from Duke University and has worked with Ernst & Young.



# Agenda



## Thursday, 18 June

- Introduction  
1700 - 1705
  - Overview  
1705 - 1745
  - Advanced Refractories  
1745 - 1815
  - Steel Flow Control  
1815 - 1845
  - Foundry  
1845 - 1915
  - Wrap up  
1915 - 1920
  - Drinks  
1930 - 2000
  - Dinner  
2000 - 2200
- Virginia Skroski  
*Investor Relations Manager*
- François Wanecq  
*Chief Executive*
- Tanmay Ganguly  
*President, Advanced Refractories*
- Chris Abbott  
*President, Steel Flow Control*
- Glenn Cowie  
*President, Foundry*
- Virginia Skroski  
*Investor Relations Manager*
- Sokrates Foyer
- Sokrates Dining Room

## Friday 19, June

- Breakfast  
0730 - 0815
  - Overview of day  
0825 - 0830
  - China  
0830 - 0900
  - Research & Development  
0900 - 0930
  - Technical Services  
0930 - 1015
  - Financial Strategy  
1015 - 1030
  - Questions  
1030 - 1100
  - Depart for GIFA / METEC  
1100
- Main restaurant
- Virginia Skroski  
*Investor Relations Manager*
- Roel van der Sluis  
*President, China and North Asia*
- Alan Charnock  
*Chief Technology Officer*
- Luis Reyes  
*President, Technical Services*
- Chris O'Shea  
*Chief Financial Officer*
- François Wanecq  
*Chief Executive*

# Organised into 4 business segments

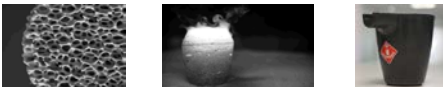
	Steel			Foundry
	Steel Flow Control	Advanced Refractories	Technical Services	Foundry & Fused Silica
Revenue <sup>1</sup> (% of group)	<b>£536m (36%)</b>	<b>£436m (29%)</b>	<b>£47m (3%)</b>	<b>£463m (31%)</b>
Overview	Provides products, systems and services to regulate and protect the flow of steel in the continuous casting process	Provides installation expertise and materials that withstand extreme temperatures and offer corrosion resistance at our customers' facilities	Provides equipment and services that capture data in the metal production process and supports decision making in process management	Improves casting quality and foundry process efficiency through the supply of products and application engineering to the global foundry industry
Products	<p>Nozzles      Tube Changers</p> 	<p>Lining      Precast</p> 	<p>Lasers      Probes &amp; Measurement</p> 	<p>Filters      Feeding Systems      Crucibles</p> 
End Markets <sup>2</sup>	Steel (100%)	Iron & Steel (75%) Cement, Aluminium (25%)	Steel (100%)	Vehicles (40%), Power Generation (7%), Mining (7%), Aluminium (10%) Glass (5%) Other (31%)
Employees <sup>2</sup>	4,820	2,840	710	3,410

Notes  
<sup>1</sup> FY 2014 Proforma Revenue including additional £37m of revenue relating to: Sidermes 2014 Revenue (£18m); and pre-acquisition revenue of £19m from Ecil MET Tec and Process Metrix  
<sup>2</sup> Vesuvius estimates  
<sup>3</sup> Proforma as at 30 April 2015, including approximately 200 employees for Sidermes

# Since demerger

- Improved trading performance
  - Headline trading profit<sup>(1)</sup>, up 25% on an underlying<sup>(2)</sup> basis vs 2012
  - Headline return on sales<sup>(1)</sup> improved by 179 basis point on an underlying<sup>(2)</sup> basis vs 2012
- Restructured the portfolio
  - Sold Precious Metals Division
  - Divested lower margin non-core businesses (VGT Dyko, Andreco Hurl, Canada construction)
- Developed a new strategy targeting Technical Services
  - Acquired three companies to populate the Technical Services business
  - Combined with existing Accumetrix and Avemis products
- Delivered shareholder value
  - Cash conversion ratio of 93% from 2012 to 2014
  - £141m<sup>(3)</sup> returned to shareholders

<sup>(1)</sup> For definitions of non-GAAP measures, refer to note 4 of the 2014 financial statements; Headline results refer to continuing operations and exclude separately reported items

<sup>(2)</sup> Underlying basis is at constant currency and excludes separately reported items and the impact of acquisitions and disposals

<sup>(3)</sup> Dividends paid £110.7m (2013 £39.4m; 2014 £41.2m; 2015 YTD £30.1m) plus 2013 share repurchase of £30m



# Investment Case

- **Global market leader**
  - strong brands
  - long history of innovation
- **Attractive position in the value chain**
  - consumable products provided to loyal customers who understand Vesuvius' technical differentiation
  - our products are a small element of our customers' costs but critical to their end product
- **Good medium term growth in addressable market of c.5% CAGR over next 10 years**
  - Indian steel market growth
  - transition from long to flat steel especially in China
  - increasing penetration of foundry products
- **Differentiated customer proposition underpins value pricing**
  - customer intimacy and high service levels given "factory floor presence" at customer sites
  - high engineering content with bespoke products
  - reputation for quality and reliability essential for safety critical products
  - global manufacturing footprint to support global customers
- **Margin improvement over the medium term**
  - operational excellence / cost leadership
  - enhancing product mix
  - operational gearing
- **Medium term opportunity in Technical Services**

# Underlying markets will grow about 5% (CAGR) in the mid term

- Key growth support factors
  - India steel production growth episode anticipated soon
  - China transformation to flat steel is underway
  - Competition between steel and aluminium will serve our markets
  - Foundry should replicate steel growth
    - Chinese foundry growth not completed yet
    - India growth potential
    - Conversion to quality castings in these markets, yet to happen
  - Antipollution regulations and energy saving pressure will demand continued improved casting technologies (ductile iron growth)
- We will keep outperforming our underlying markets



# In Foundry we overperformed the market in most areas

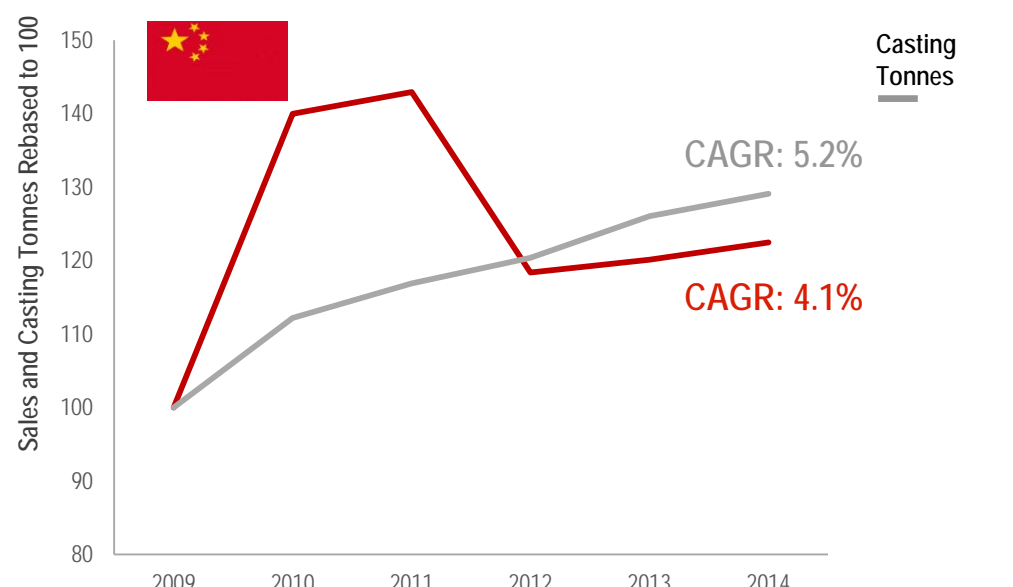
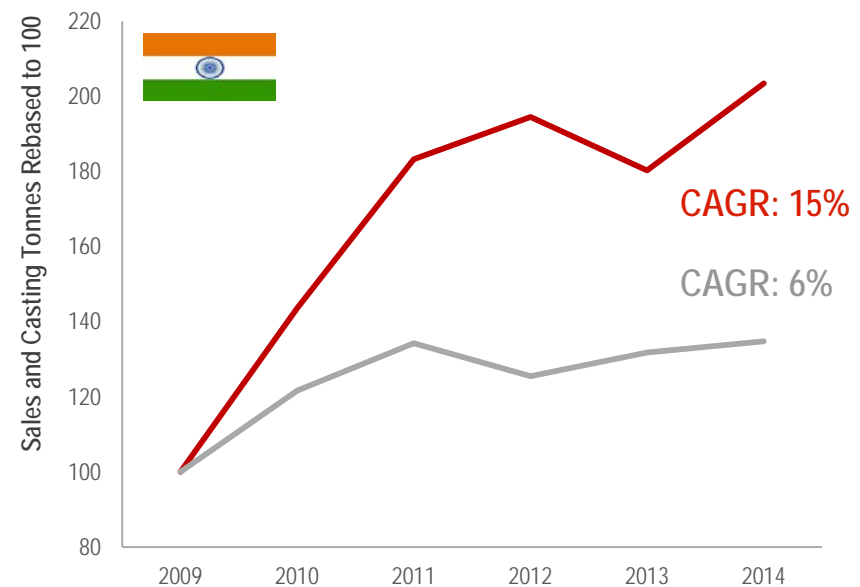
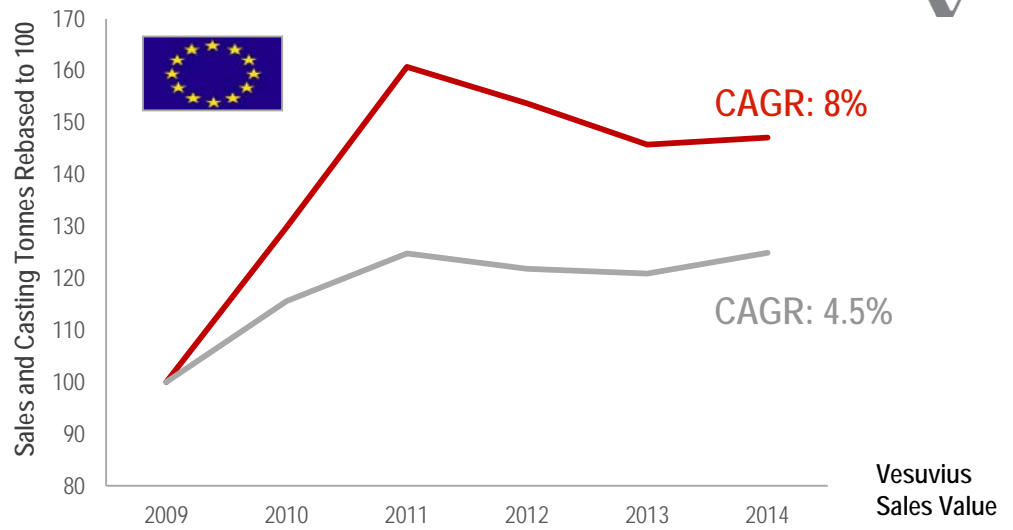
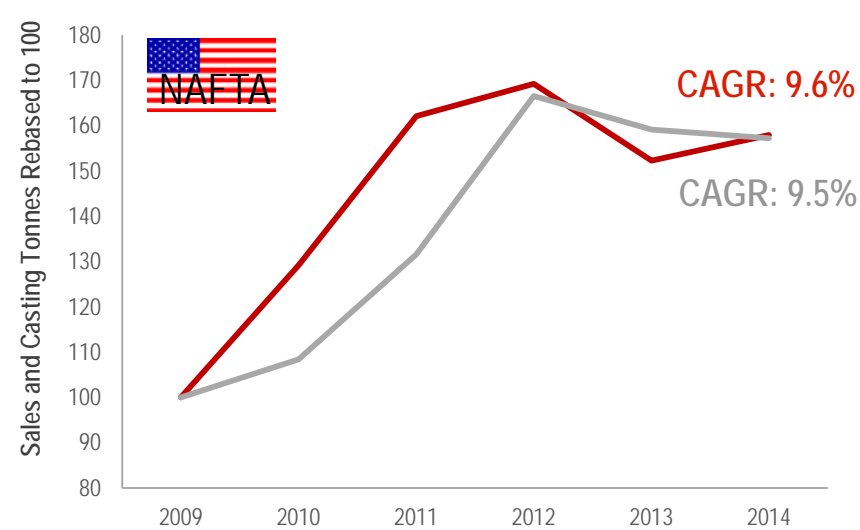

Source: Modern Casting and Vesuvius estimates for casting tonnes, Vesuvius internal data for Vesuvius sales at constant currency



# Long term growth in Foundry will come from innovation and marketing

Foundry sales  
£/T of total market casting (2013)

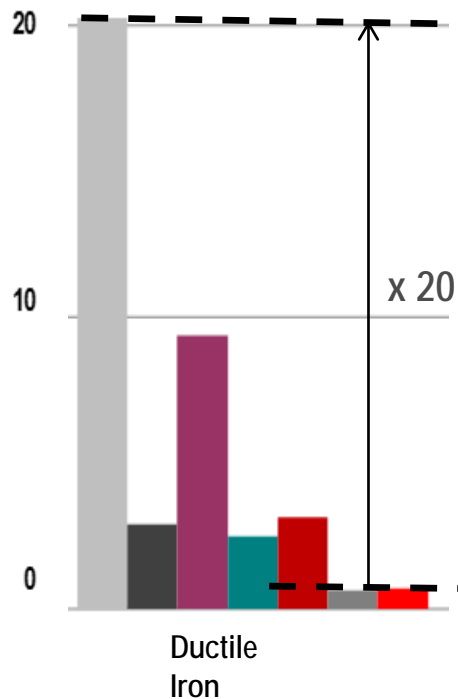

Significant upside potential through continuing market penetration as emerging markets move towards higher quality foundry castings

- Northern Europe
- South America
- Japan
- NAFTA
- India
- CEME
- China

# Evidenced as well in steel where we overperformed the market

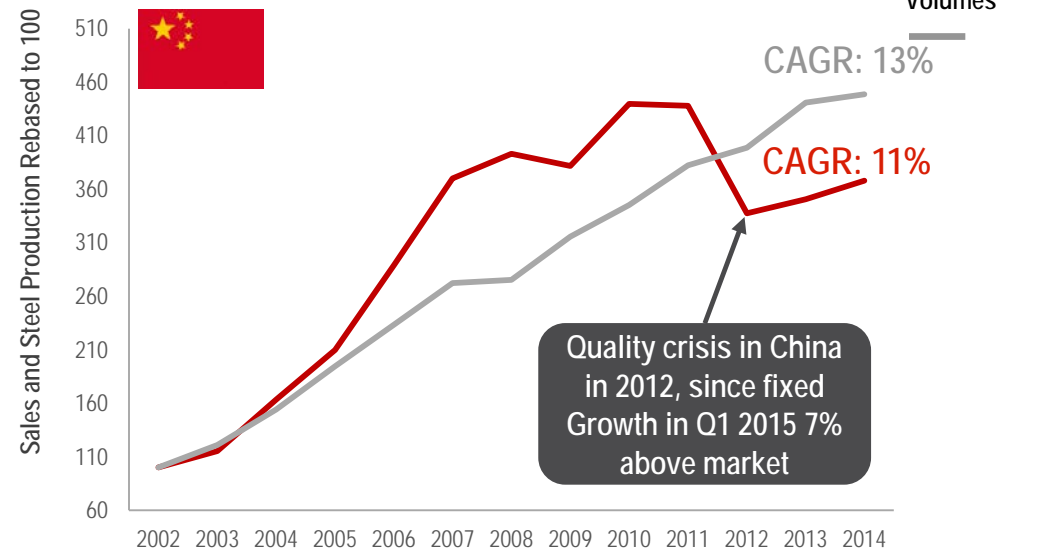
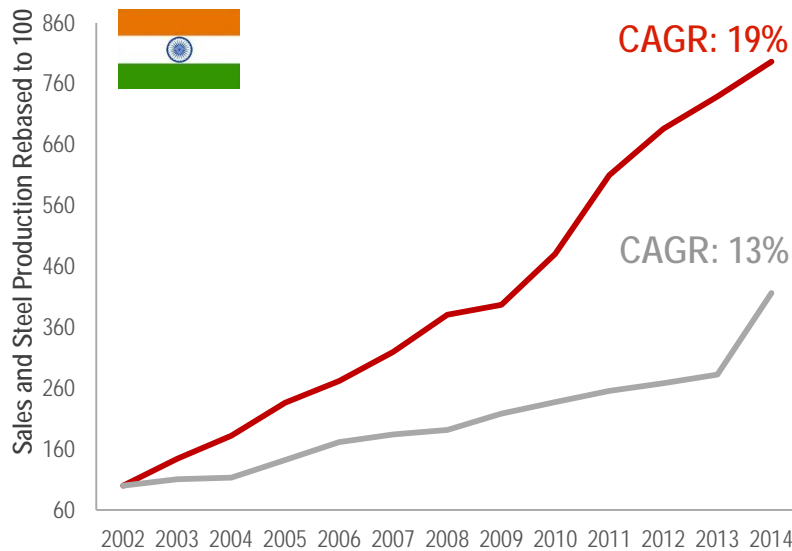
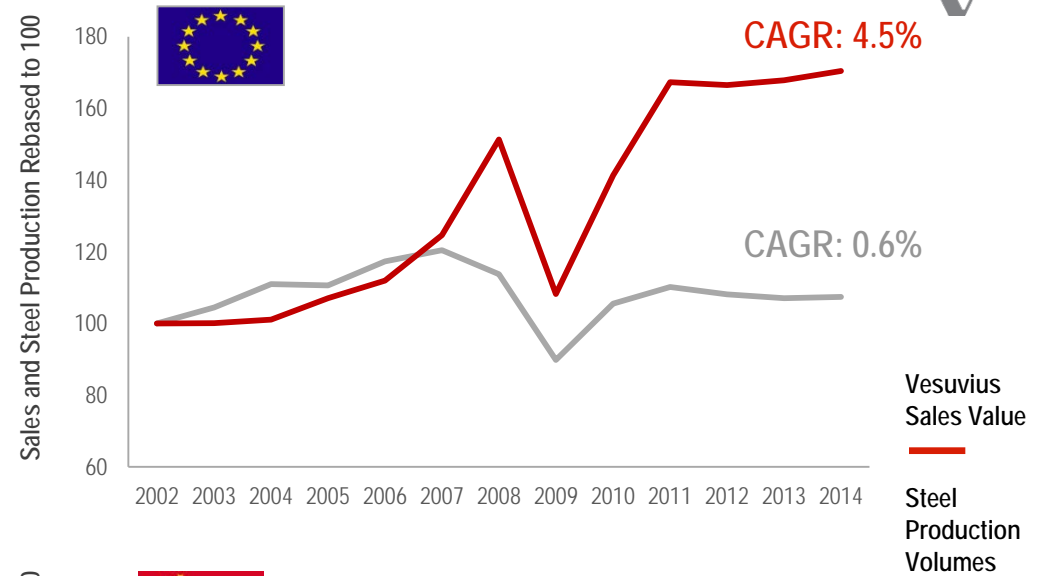
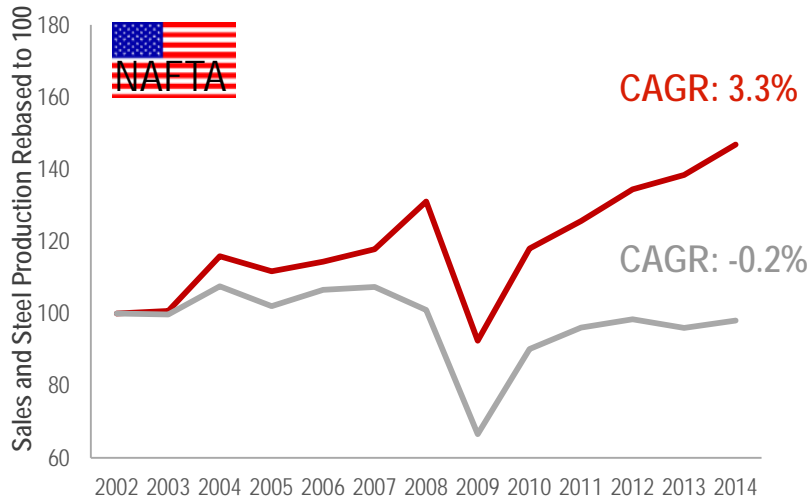

Source: WSA for steel production volumes, Vesuvius internal data for Vesuvius sales at constant currency. Note 2002 figures are rebased to 100



# Steel and Foundry industries trends to remain similar

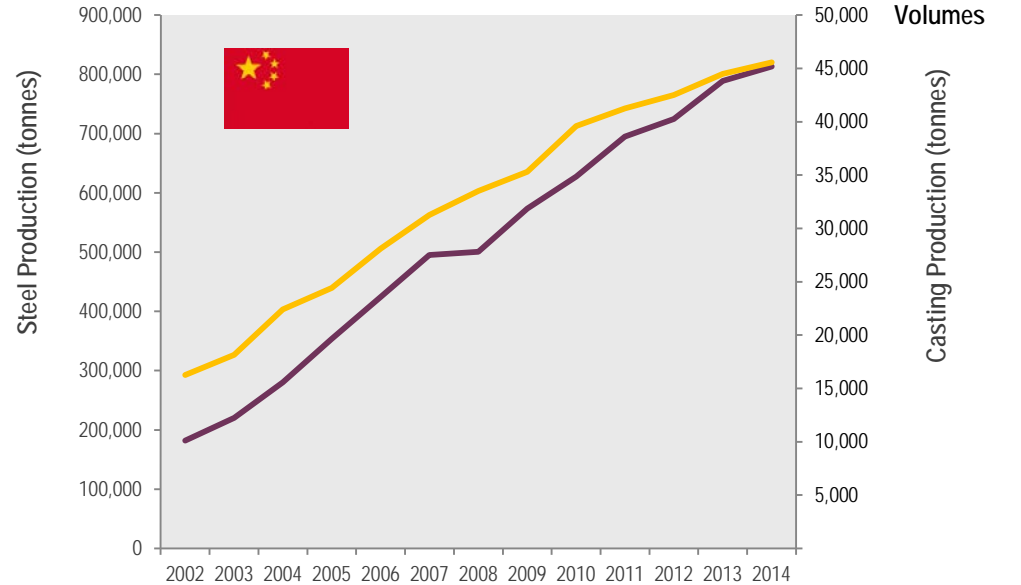
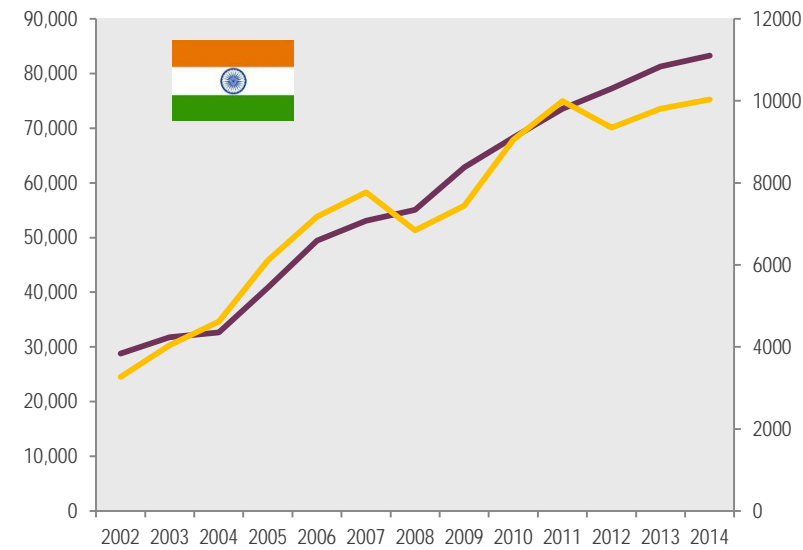
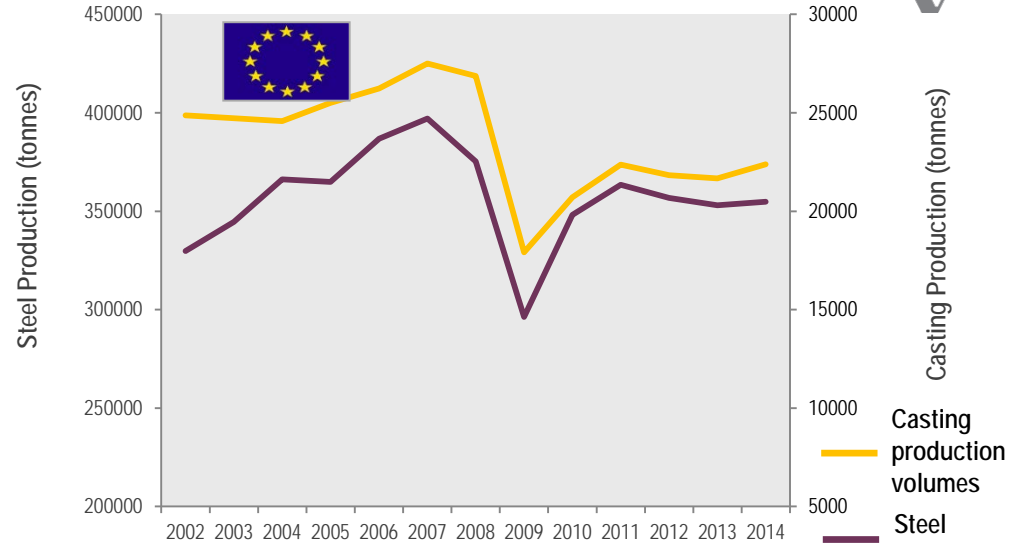
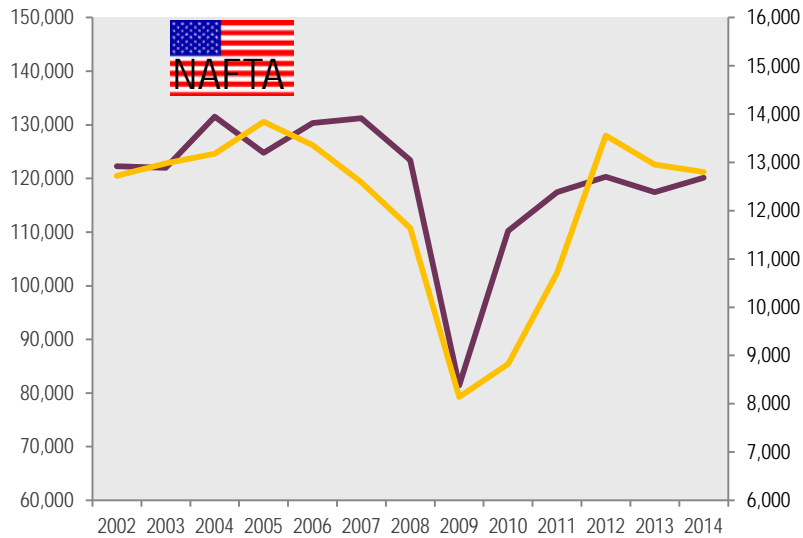

Source: WSA for steel production volumes; Modern Casting and Vesuvius estimates for casting tonnes

# Growth in steel markets

- The steel market should grow from 1.5 to 2 billion tonnes in the next decade based on growth in Indian steel production
  - India should offer the potential for £200m additional Vesuvius sales over 10 years
- Transformation of the Chinese industry from long to flat steel delivers a potential doubling of the accessible market for Vesuvius



# Steel Production Volume Trend

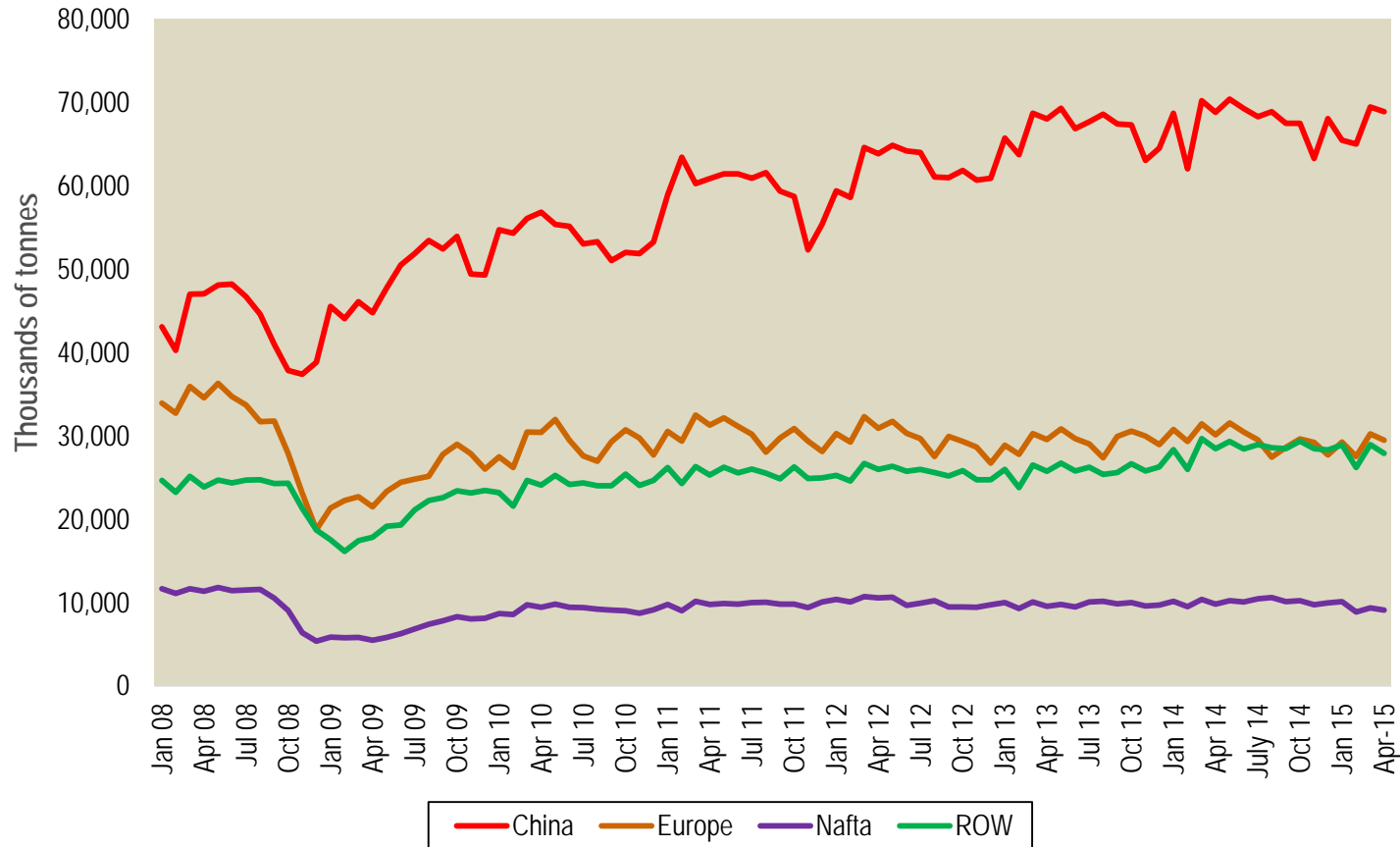

## Since 2008

- China has grown 60%
- Europe has shrunk 15%
- NAFTA has shrunk 20%
- Rest of World grew 15%





# China Steel Production: Has the limit been reached? Parallel with Japan

End of high GDP growth period

Japan – Steel production vs GDP growth

China – Steel production vs GDP growth

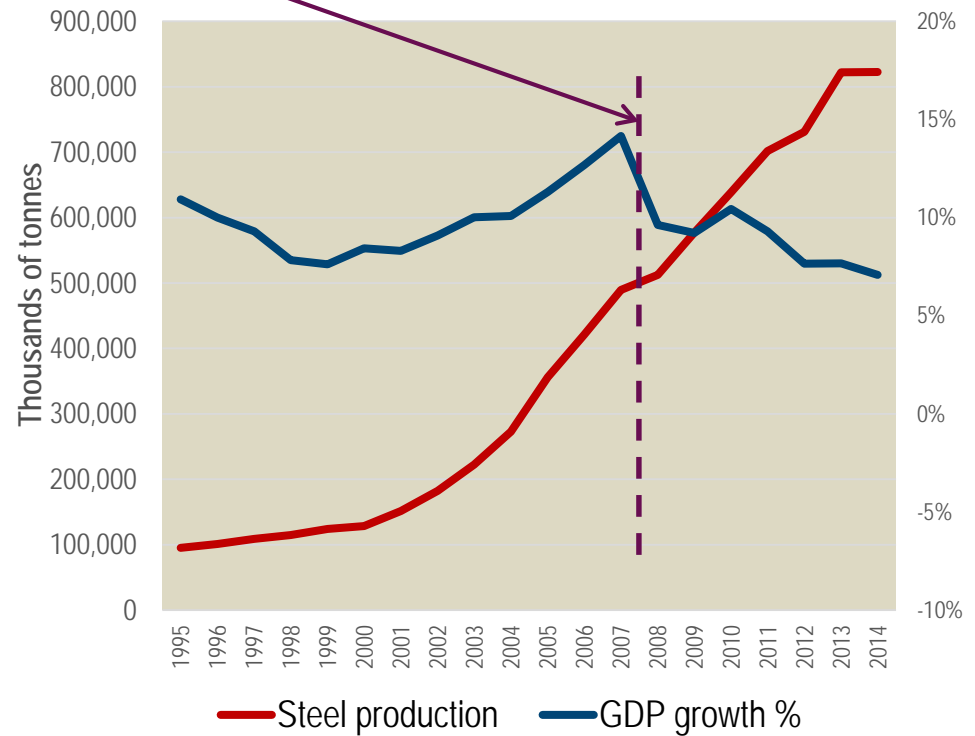
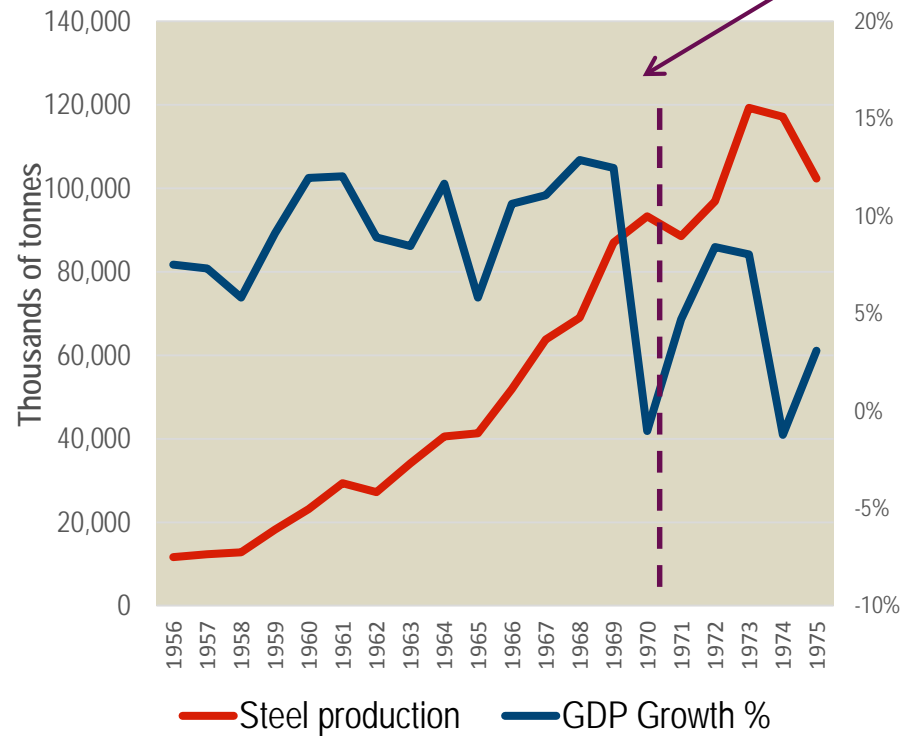

Steel production per capita in Japan 870kg

Steel production per capita in China 610kg

From 1956 to 1973 (18 years) steel production multiplied by a factor of 10

From 1996 to 2013 (18 years) steel production multiplied by a factor of 9

# What is the steel profile of a maturing economy: the case of Japan

## Japan – Steel production vs GDP growth

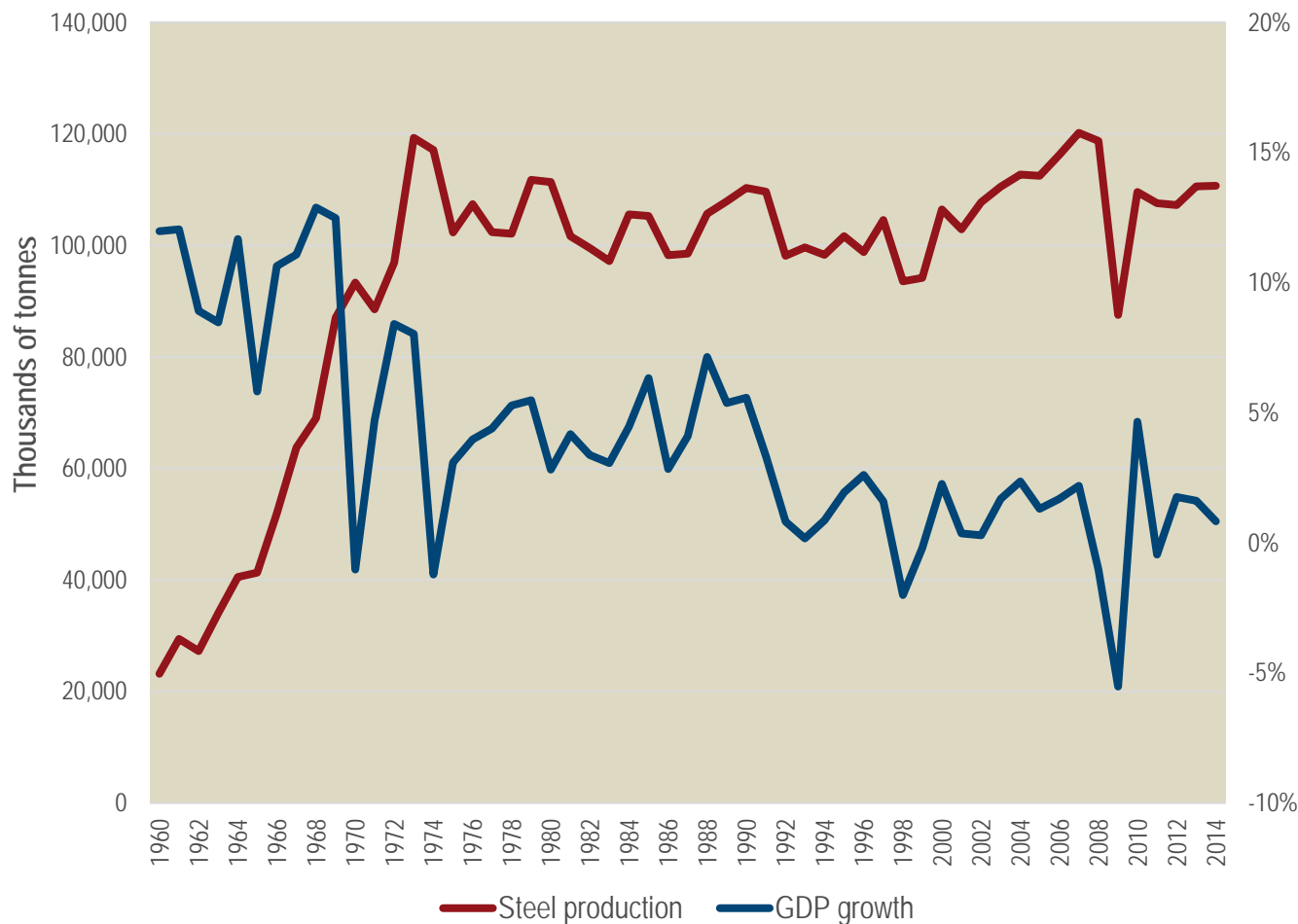

- Steel production per capita in Japan 870kg
- After the peak in 1973 steel production declined a little and recovered to about 90% of peak over 40 years

# The Indian steel production high growth sequence should start soon

## India – Steel production vs GDP growth

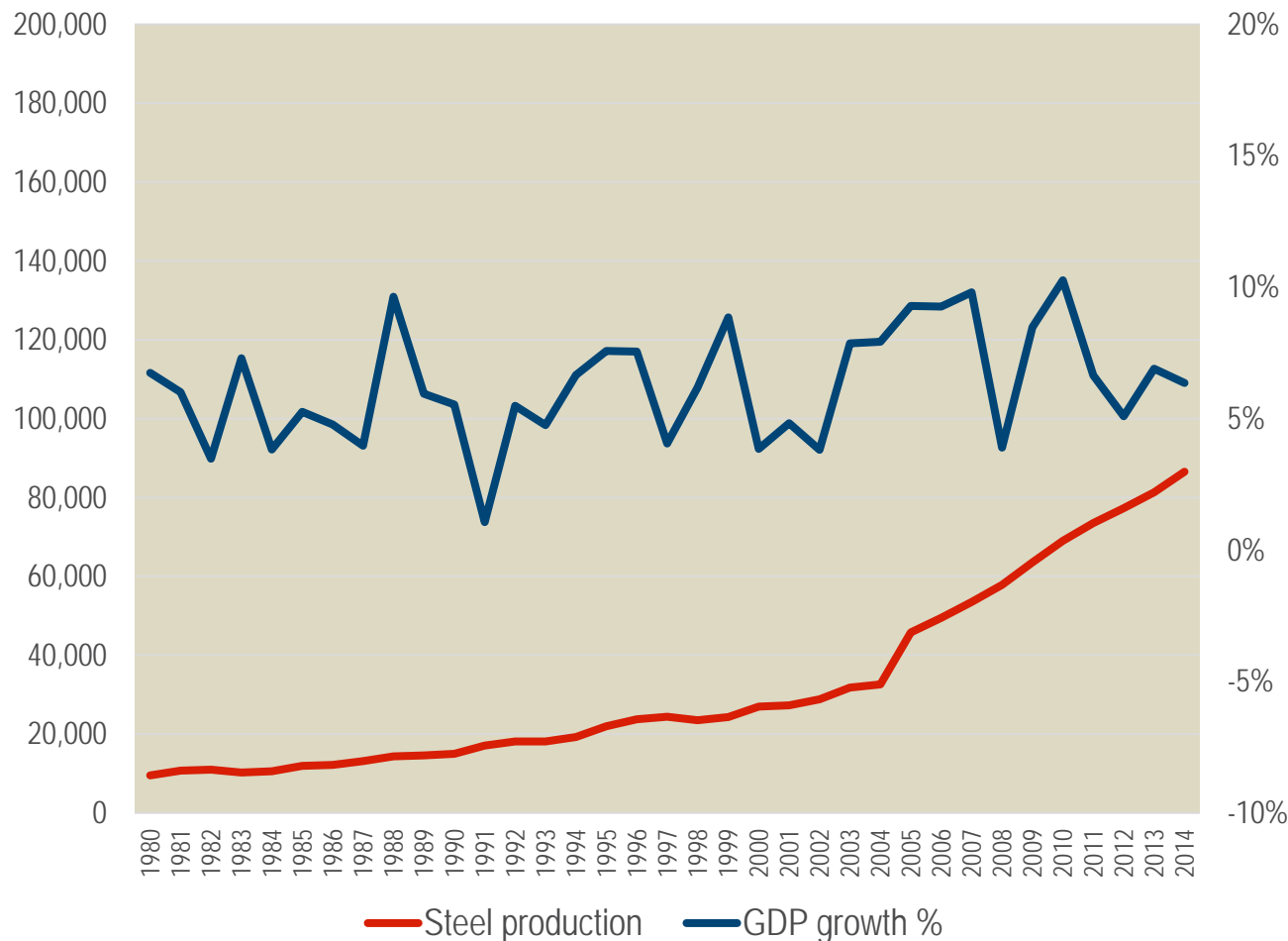

- Steel production per capita in India 70kg (vs 610kg in China)
- The long term steel growth episode should start in the coming three years and take longer than in Japan and China
- Official objective is 300 million tonnes in 2025

# Mid term conversion of China to a consumer driven economy opens a considerable growth potential (up to £400m+ revenue)

Proportion of flat vs long steel by region (2014)

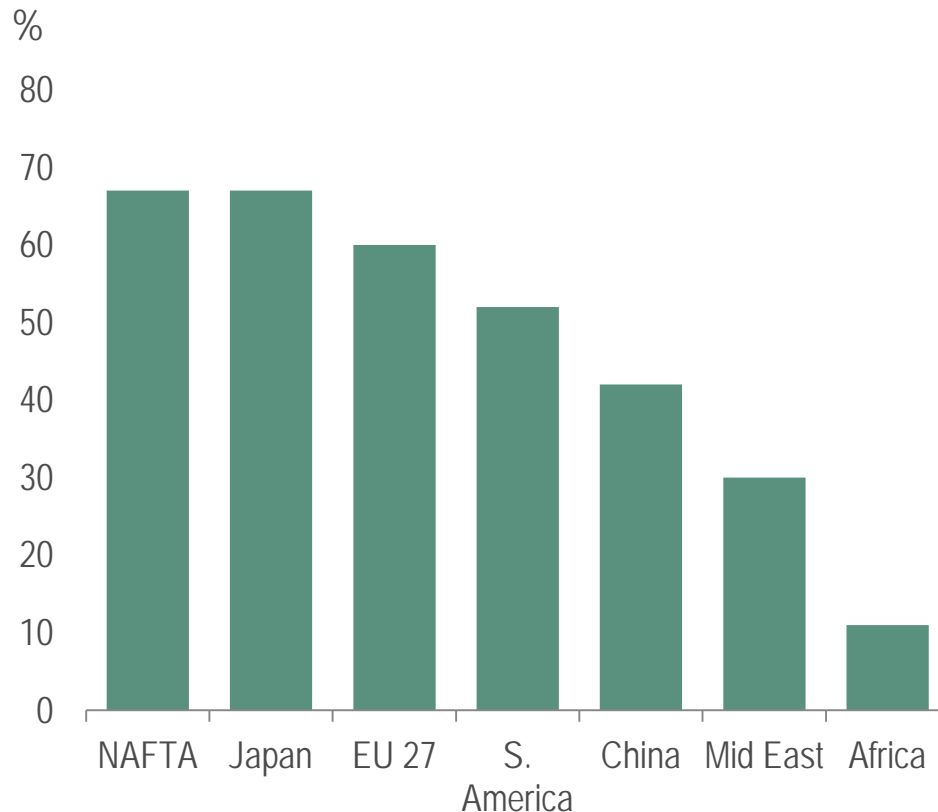

- Chinese economy moves from investment driven towards consumption driven
- Investment consumes predominantly long products while consumption is more on flat steel (cars, domestic appliances)
- Over the years, its ratio of flat to long products will move from 40/60% as now towards 65/35% as in NAFTA
- Today Vesuvius Flow Control sells £50m to China and £500m to the rest of the world



# Steel market growth scenario

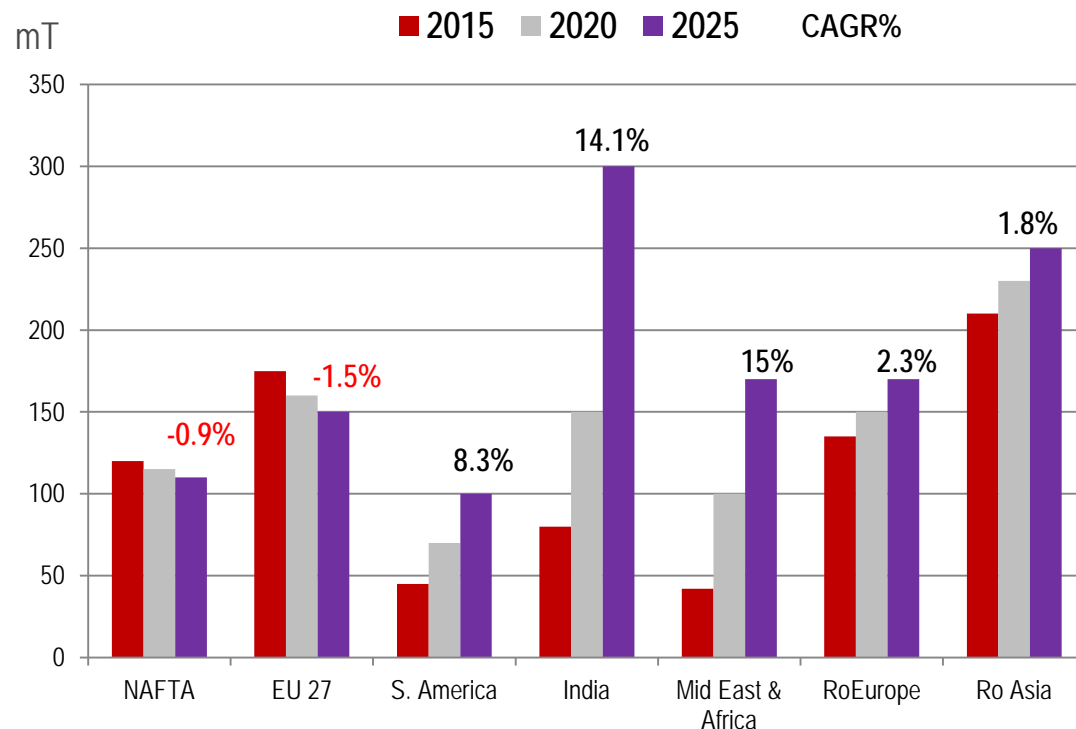
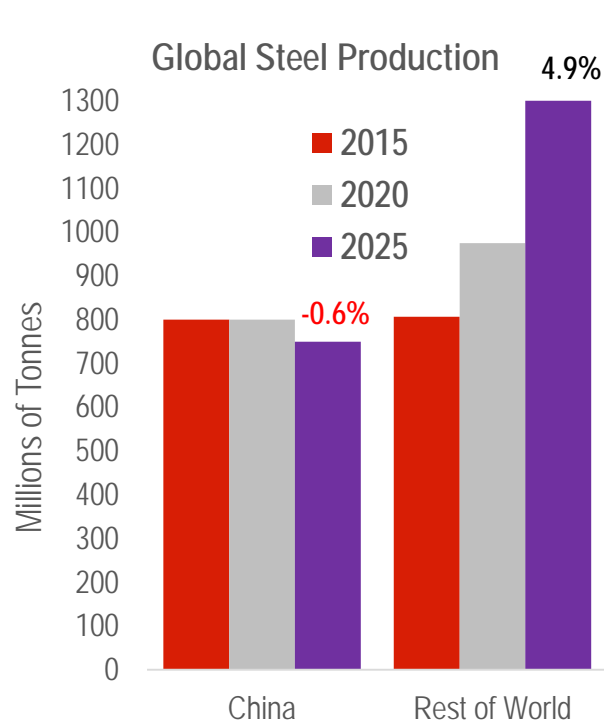

## Global forecast production

2016 – 1.6 billion tonnes  
 2020 – 1.8 billion tonnes  
 2025 – 2.0 billion tonnes

- NAFTA and Europe should decrease slowly as their economic growth model requires less steel
- China stabilises and starts declining at the end of the period
- India enters in a major steel growth episode
- South America, Middle East and at the end of the period, Africa, enjoy sustained growth

# Conversion to flat steel is a growth opportunity

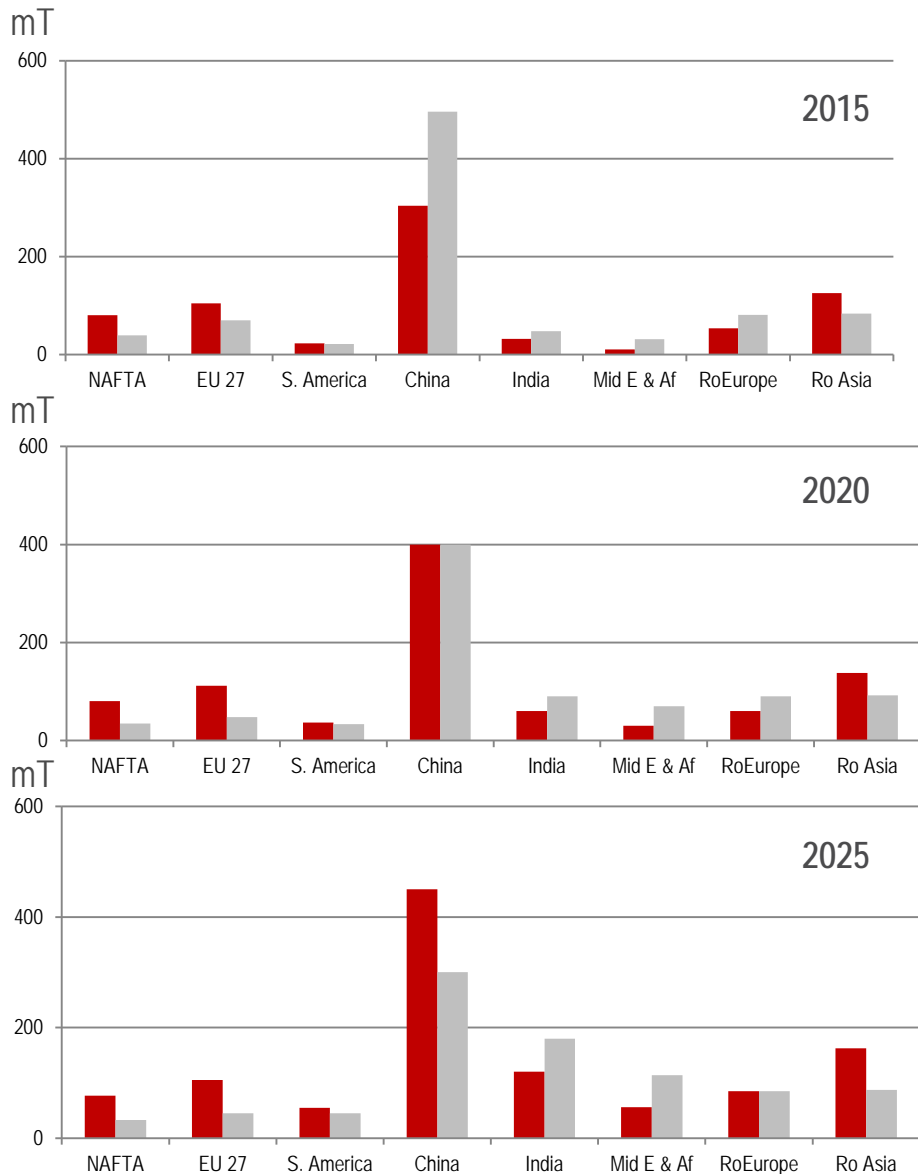

- Progression of flat steel vs long steel could generate growth in our accessible market of 30% in 2020 and 55% in 2025
- In the same period global steel production is expected to grow by only 10% and 28% respectively

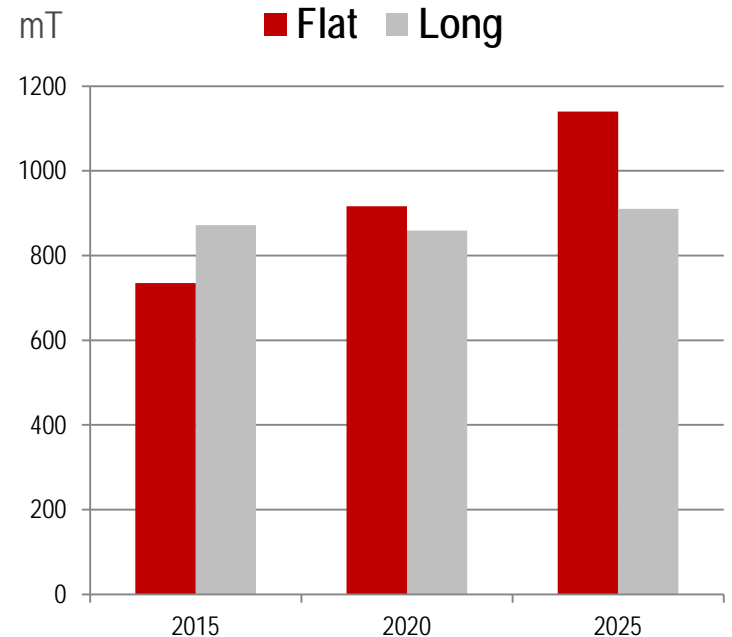

# Conclusions

- The steel market should re-start a growth episode during the next decade based on an Indian steel growth period, and reach 2 billion tonnes annually
- Transformation of the Chinese industry from long to flat steel delivers a potential doubling of the accessible market for Vesuvius
- India should offer the potential for £200m additional sales over 10 years

## Consequences for Vesuvius

- Flow Control should enjoy an underlying revenue growth of 5% CAGR
- Advanced Refractories revenue growth will be closer to 2% CAGR as we focus for the high margin business rather than volume



# Steel vs Aluminum: Parallel growth

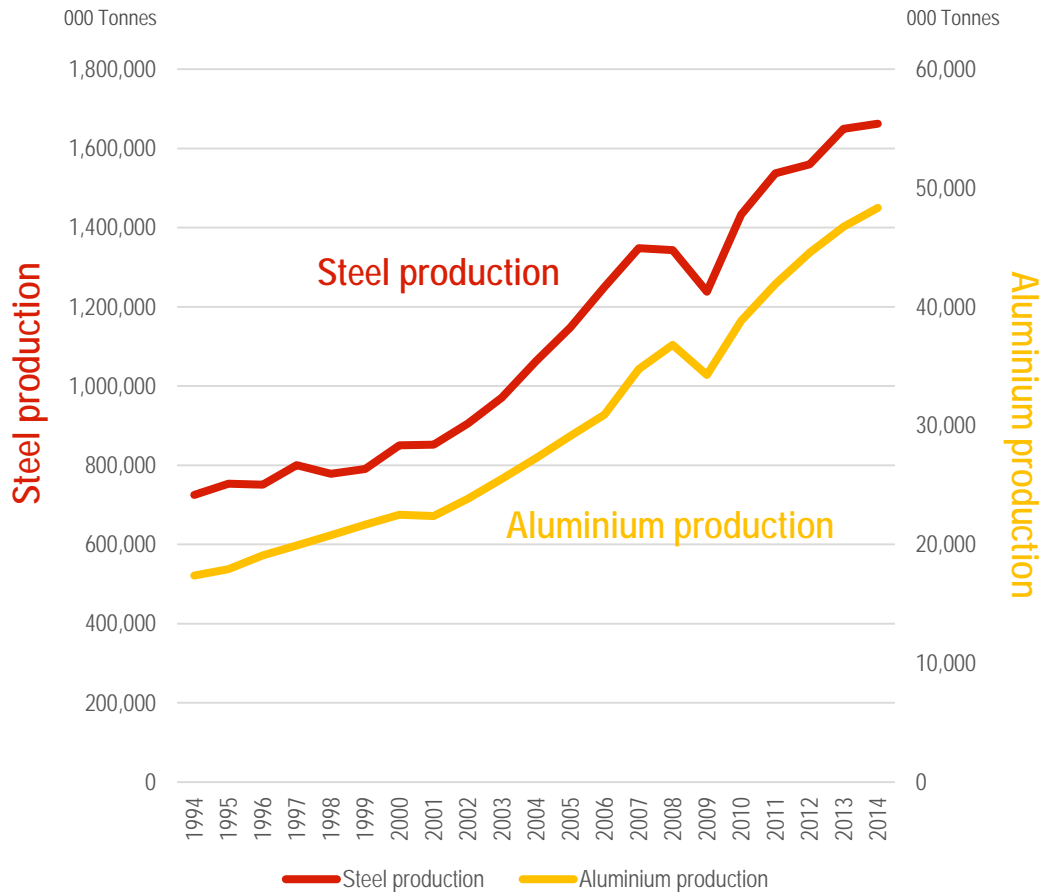

Aluminium production by region – 2014

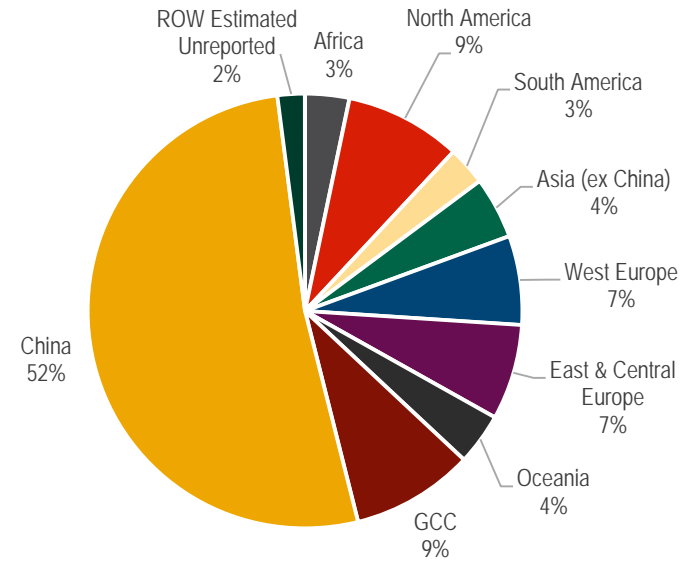



# Steel vs Aluminium: Growth of high-strength steel is an opportunity

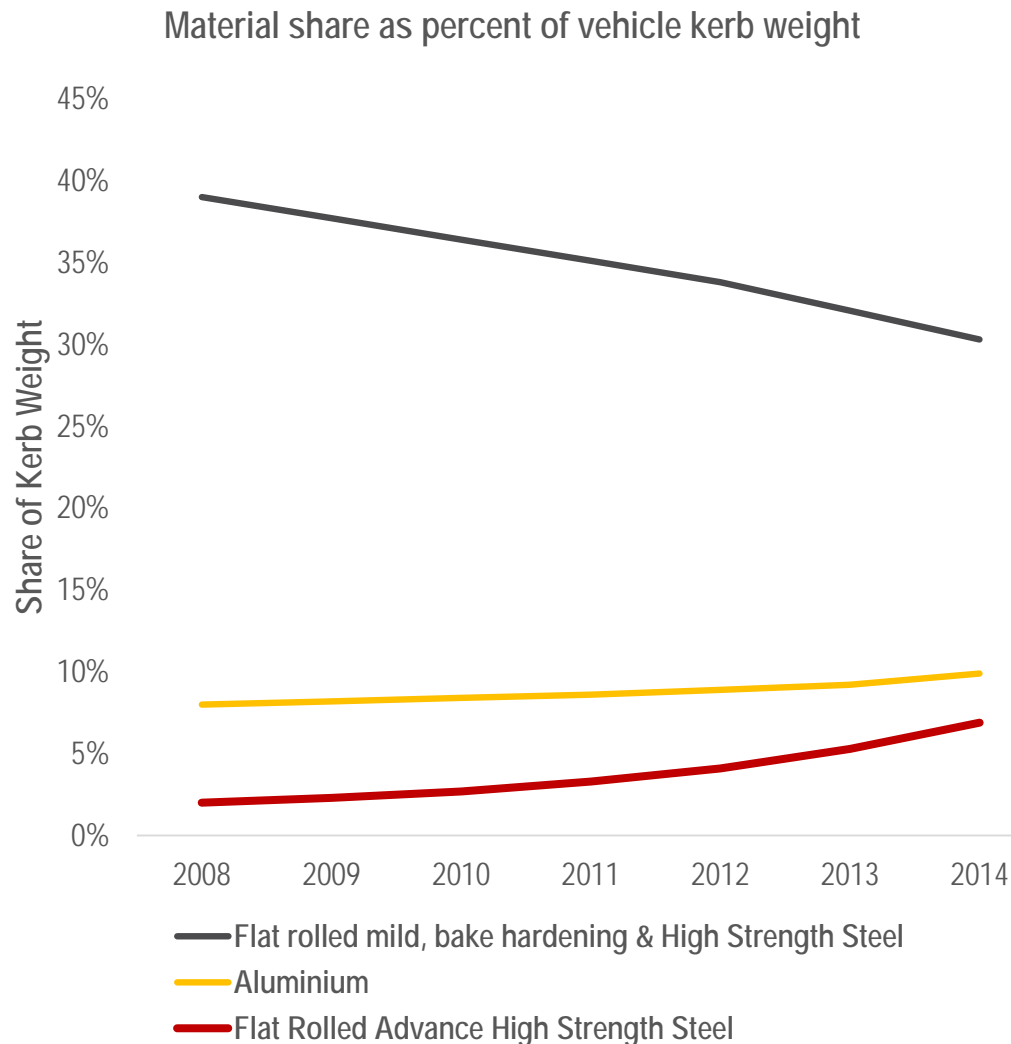

In vehicle production, conventional steel is replaced by high-resistance steels as well as by Aluminium

- High resistance steels require more sophisticated technologies to be produced (high Ni or Mn content) and tighter control on the process
- Today the most advanced steel makers suffer very low productivity on such qualities

Source: <http://www.drivealuminium.org/vehicle-uses>

# Steel vs Aluminum: Long term forecasts give the major share to high strength steels for light vehicles

Material share as percent of vehicle body weight

2012

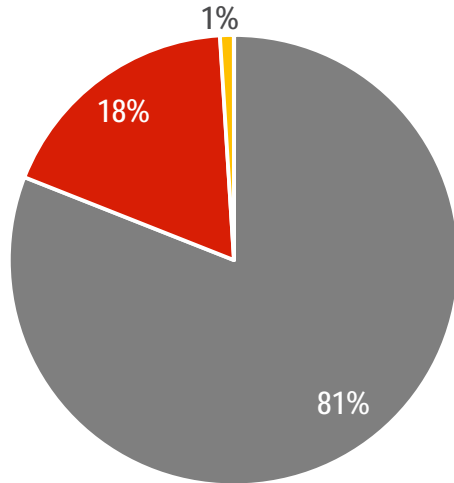

2015

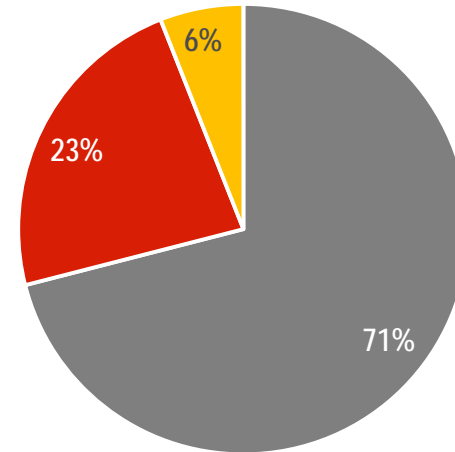

2020

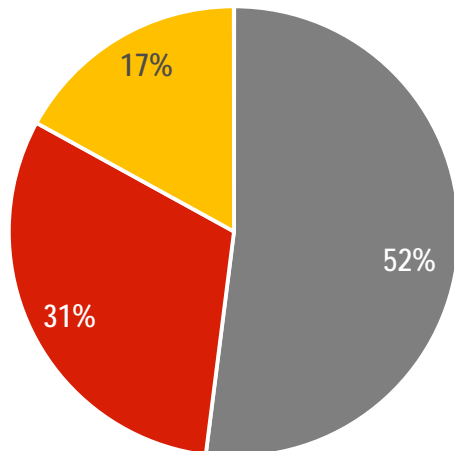

2025

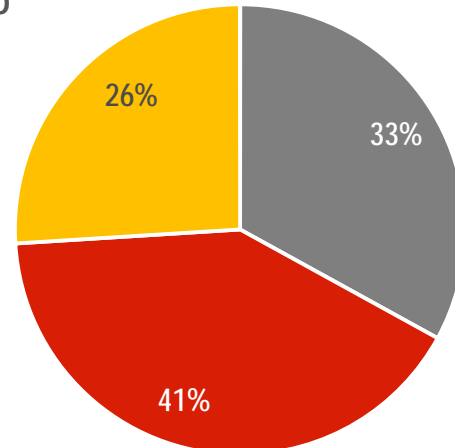

- Mild and High Strength Low Alloy
- Advanced High Strength Steel / Ultra High Strength Steel
- Aluminium

# Conclusion

---

- The shift to high strength steel should compensate Vesuvius for the penetration of Aluminum in the car industry. Vesuvius can expect a higher spending on refractory engineered solutions for these new demanding qualities



# Delivering on the strategy

- Maintain technology leadership

- Increase penetration of value creating solutions

- Capture growth in developing markets

- Improve cost leadership

- Build technical services offering

# Manufacturing Excellence

- Since demerger we have reduced transformation costs despite the continued increase in the complexity of pieces inherent in our business
- Safety breakthrough, Quality breakthrough and Lean manufacturing plans are well embedded
- Now launched a global Excellence programme aimed at reducing waste, improving efficiency and optimising operational delivery across all activities

Conversion Costs as a % of sales

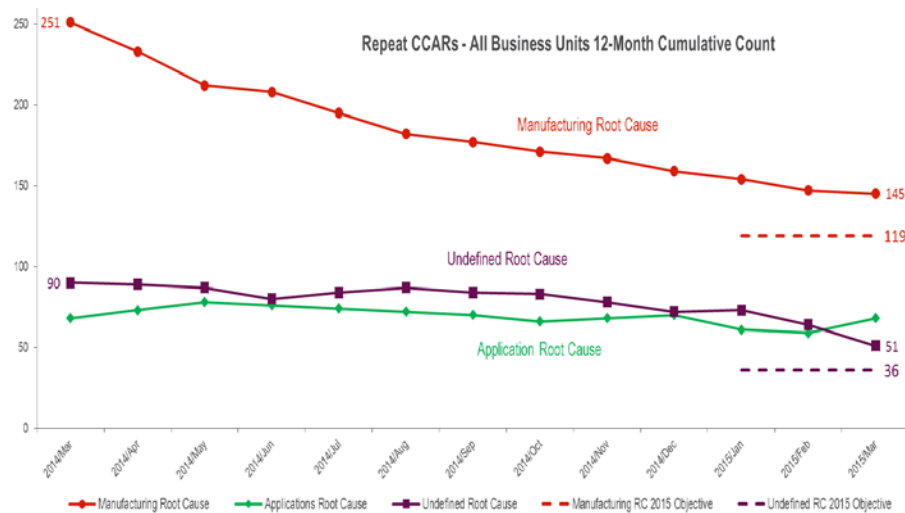
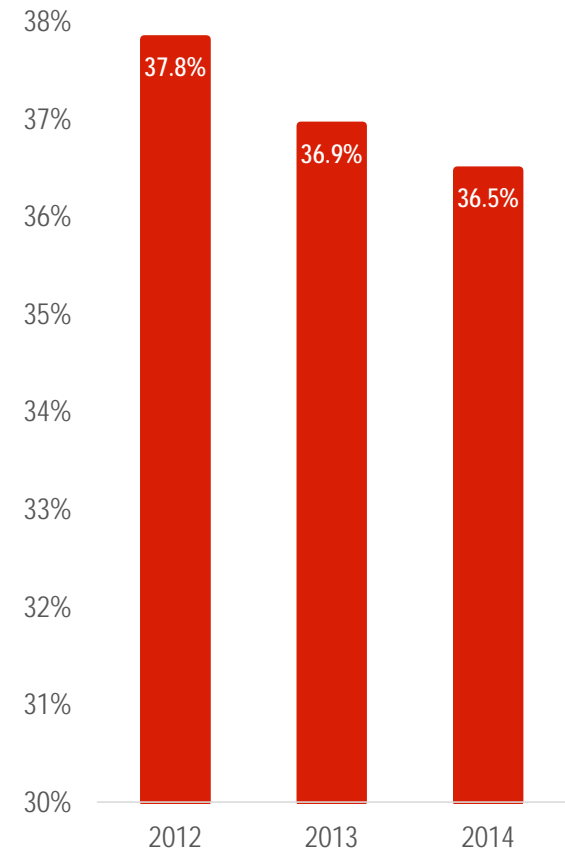

Source: Vesuvius plc

# A continued shift of operations to align with customers drives us to lower cost countries

## NAFTA facilities and headcount

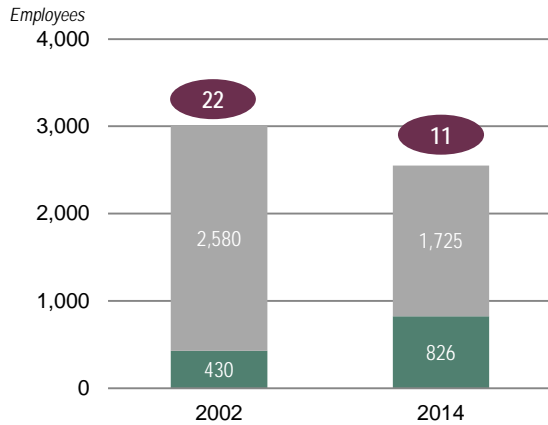

## EU 15 facilities and headcount

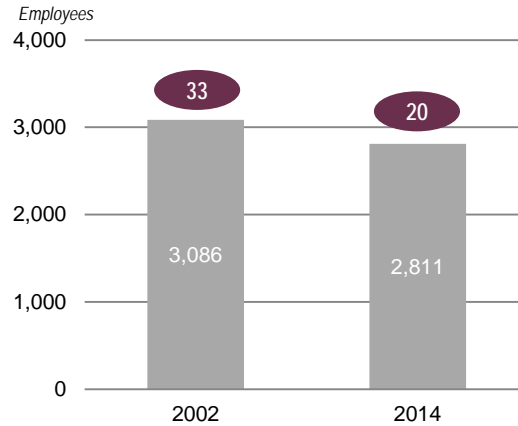

## Other EMEA facilities and headcount

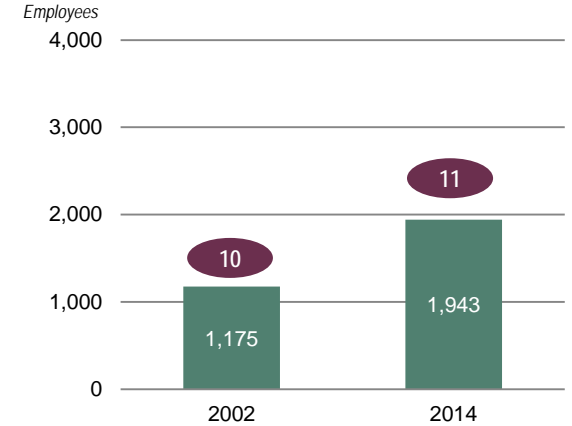

## South America facilities and headcount

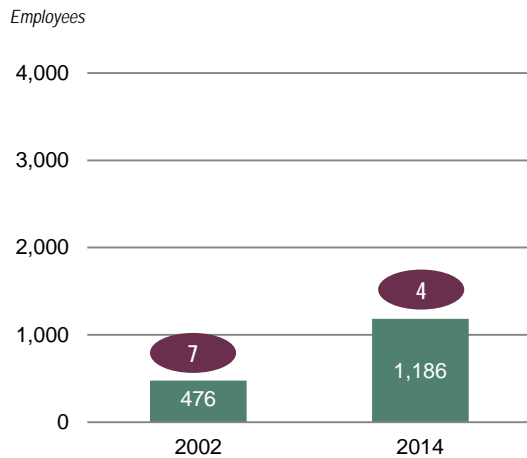

## Asia Pacific facilities and headcount

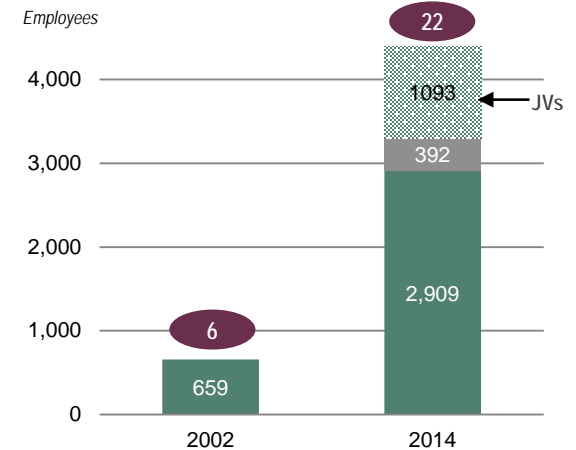

Note 2002 numbers do not include Foseco (acquired by Cookson in 2008) which had 27 sites and 3400 employees at acquisition

# We increase our R&D effort to maintain technology leadership

Sustainable growth will come first from technology

- R&D expenditure has progressed steadily since 2008
- Decision to build in Pittsburgh (USA), Enschede (NL), Vizag (India)
- Necessity to improve our ideas generation and time to market

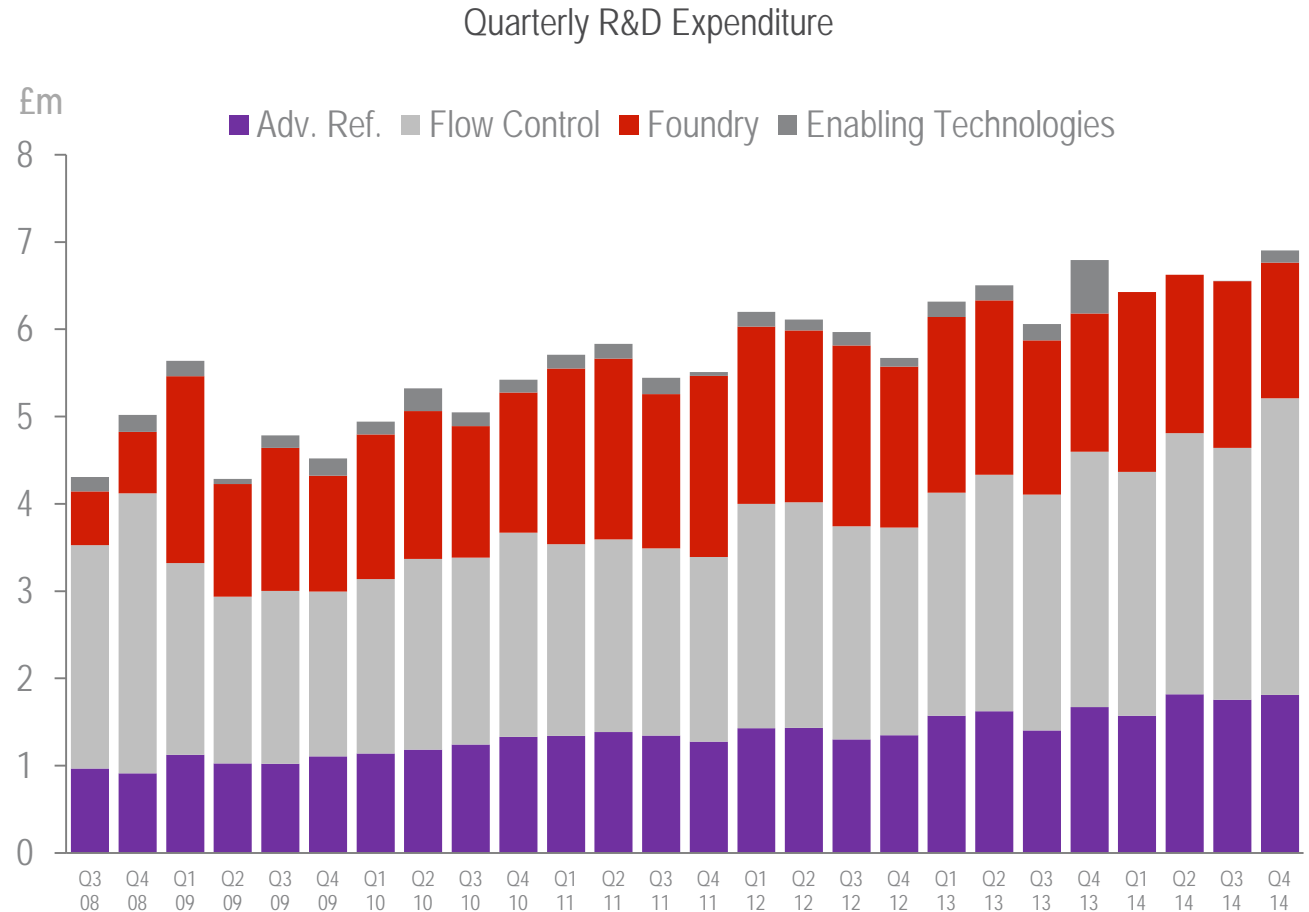

- A groupwide New Product Introduction procedure is being deployed to promote:
  - More discipline in the selection of programmes
  - A permanent review of the programme value
  - A rigorous allocation of forces to a limited number of most rewarding programmes
- Objective is to speed up the market launch of new products
- Target of 20% of total sales from new products





# Technical Services: Deliveries and potential

- Acquisitions bring us greater technological inroads and market intimacy in data capture
  - Temperature and gas content with ECIL Met Tec and Sidermes
  - Laser technology with Process Metrix
  - Integration is underway (new logo)
- New business model is under development for new products
  - Accuoptix
  - X Mat
- Further acquisitions are under review



# Going forward

- Since 2012 we have delivered on our commitments
  - streamlining the business
  - improving our margins
  - delivering shareholder value
  - positioning the company for growth
- We see significant growth potential for our markets in the mid term
  - India steel high growth sequence
  - China's transformation to consumer driven economy
  - Foundry to follow the same pattern
- We are taking the appropriate steps to capture this growth
  - Increased efforts in technology
  - Driving excellence in manufacturing
  - Developing technical services



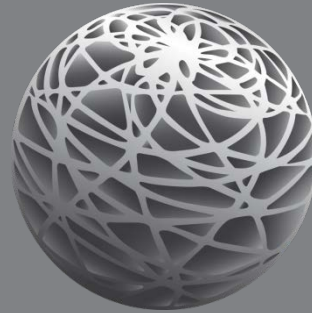

A GLOBAL LEADER IN METAL FLOW ENGINEERING

## Steel Division: Advanced Refractories

Tanmay Ganguly  
President, Advanced Refractories

VESUVIUS PLC

# Steel Advanced Refractories

---

- Main products and applications
- Facilities and headcount
- Key financials
- Strategy implementation
- Growth opportunities in Advanced Refractories



# Steel Advanced Refractories

---

- Key Points
  - Market for our products and technologies
  - How we add value to our customers
  - How do we drive profitable growth?



# Advanced Refractories – Products and Applications

Refractory Market £/T of Steel = 5 – 6

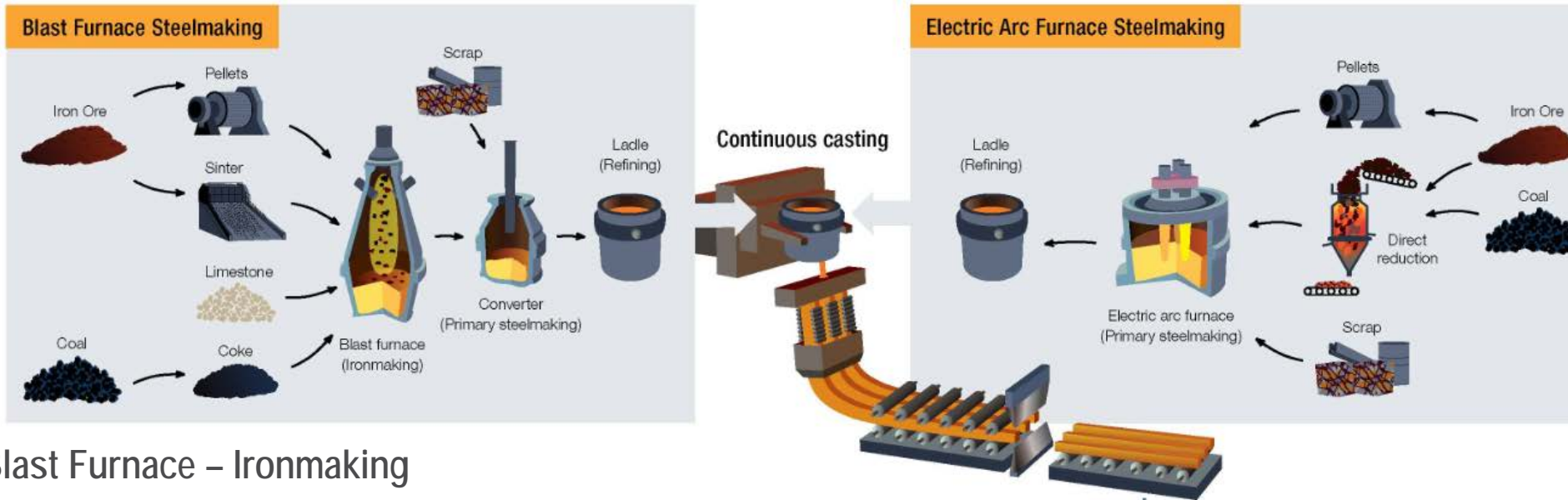

## Blast Furnace – Ironmaking

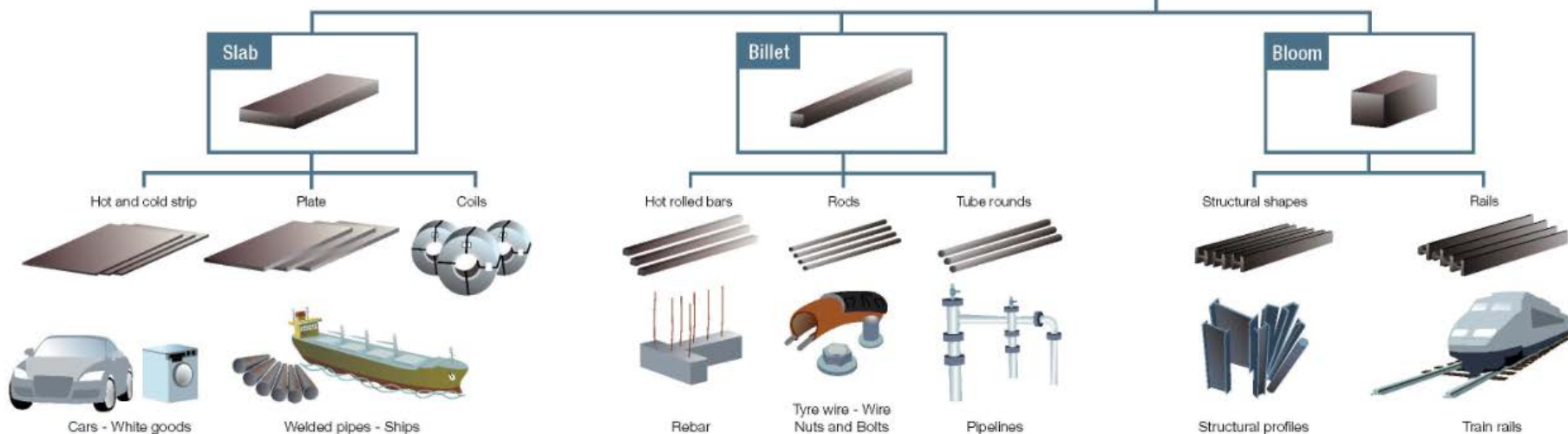

# Advanced Refractory – Steel Refractory Consumption (£/t)

■ Blast Furnace 
 ■ BOF Vessel 
 ■ EAF Furnace 
 ■ Steel Ladle 
 ■ Tundish 
 ■ Reheat Furnace 
 ■ Other

Refractory Market £/T of Steel = 5 – 6

AR products represent 80%

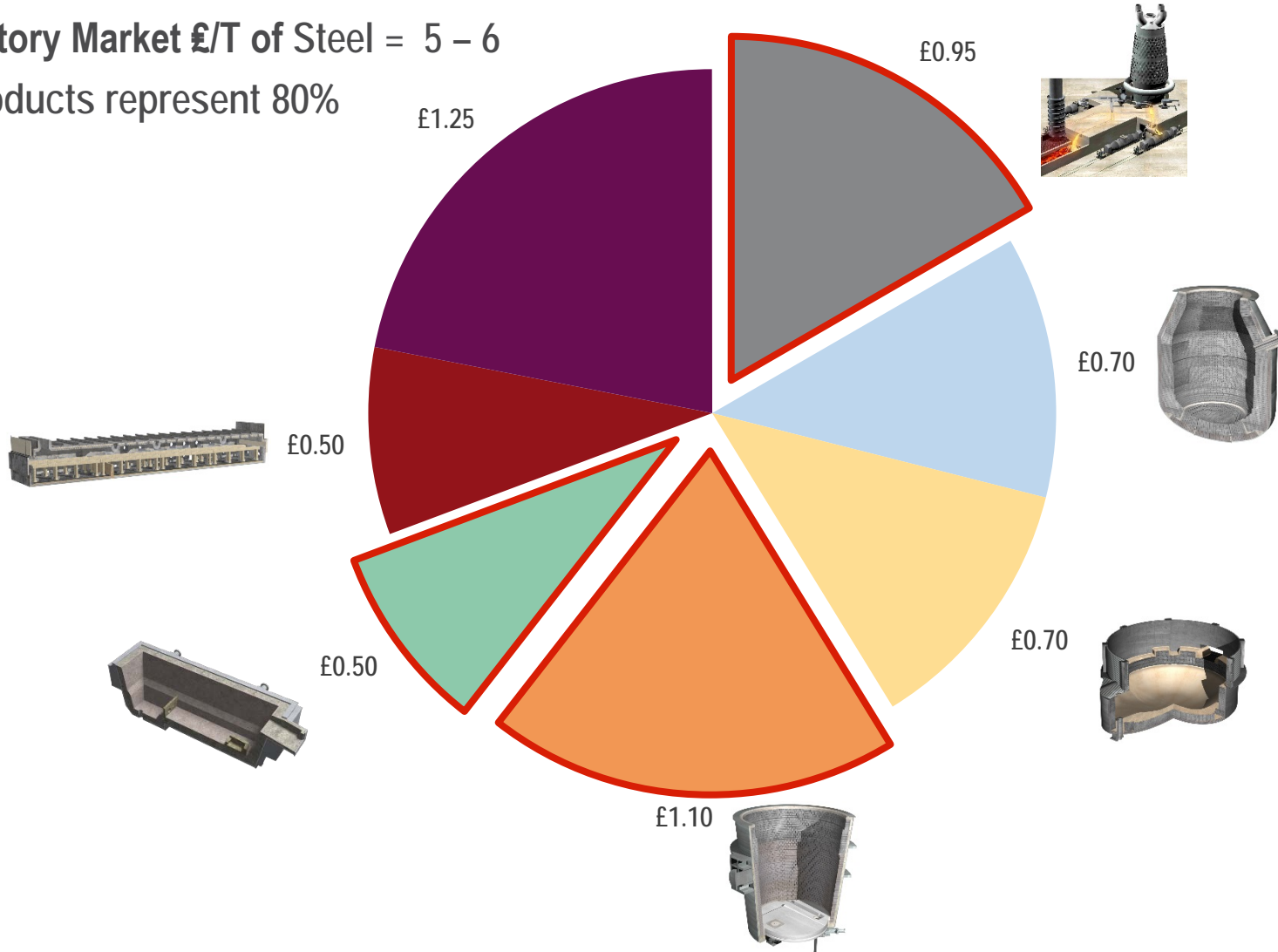

# Advanced Refractories – Products and applications

## Blast Furnace

Refractory Market £/t of Hot Metal = 0.95

### Turn-key Projects

- Complete Furnace Relines
- Stack Repair
- Taphole Clays

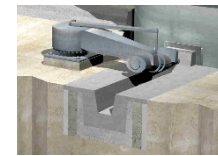

### Casthouse

- Trough
- Iron & Slag Runners

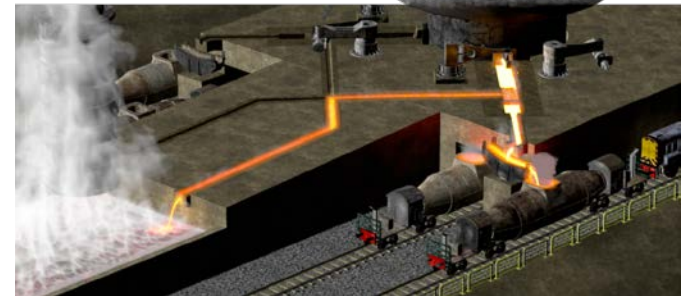

### Tilters

- Torpedo Ladle
- Iron Transfer Ladle

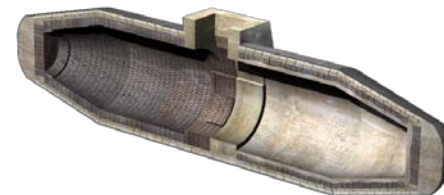



# Advanced Refractories – Products and applications

## Steel Ladle

Refractory Market £/t of Hot Metal = 1.10

### Safety Linings

- Fired Magnesia Bricks
- Fired Alumina Bricks
- Alumina Monolithics

### Working Linings

#### Slag Line

- Normally Magnesia Carbon Bricks
- Dolomite

#### Barrel

- Magnesia Carbon Bricks
- Dolomite Bricks
- Alumina Magnesia Carbon Bricks
- Magnesia Alumina Carbon Bricks
- Alumina Spinel Monolithics

### Ladle Bottom

- Magnesia Carbon Bricks
- Alumina Magnesia Carbon Bricks
- Cast-in-situ Monolithics
- ELBY™ Precast

### Maintenance Program

- Gunning Materials
- Equipment

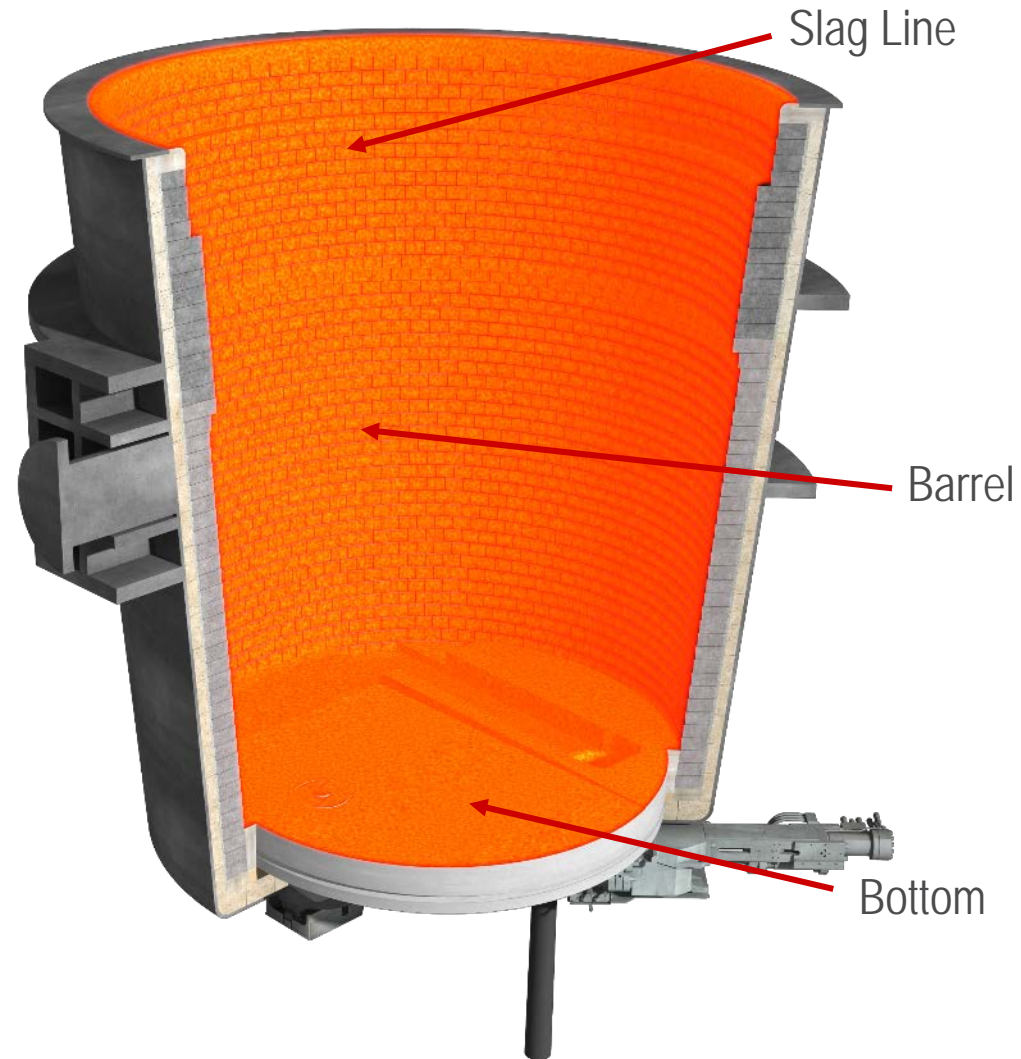

# ELBY™ Technology – Ladle simulation

ELBY™ ladle bottom significantly improves yield while decreasing ladle slag carry-over

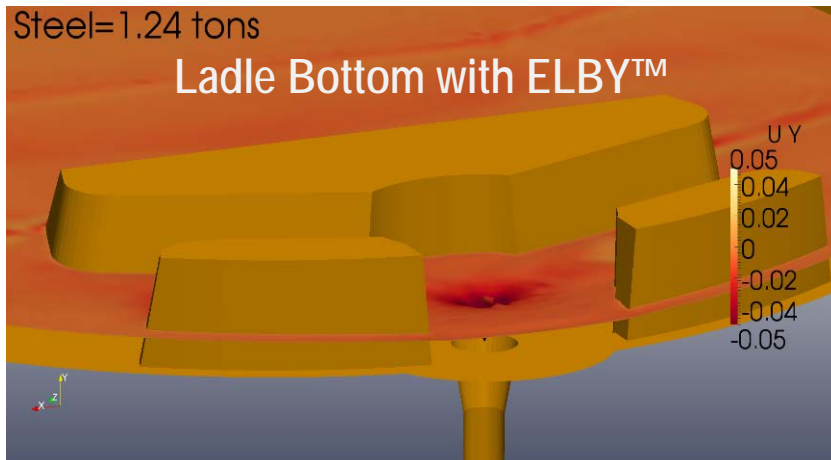
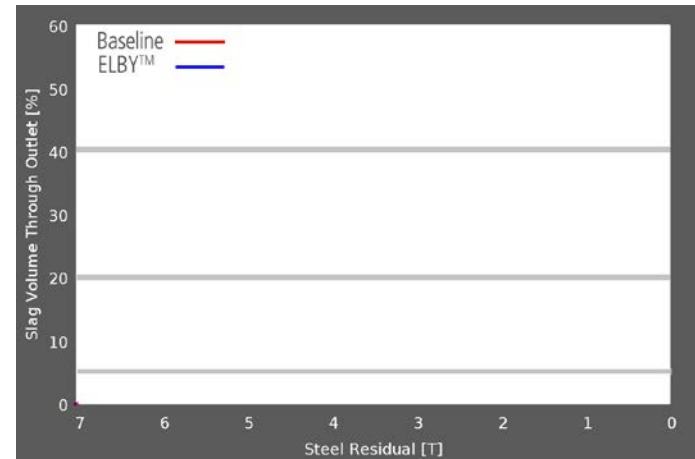
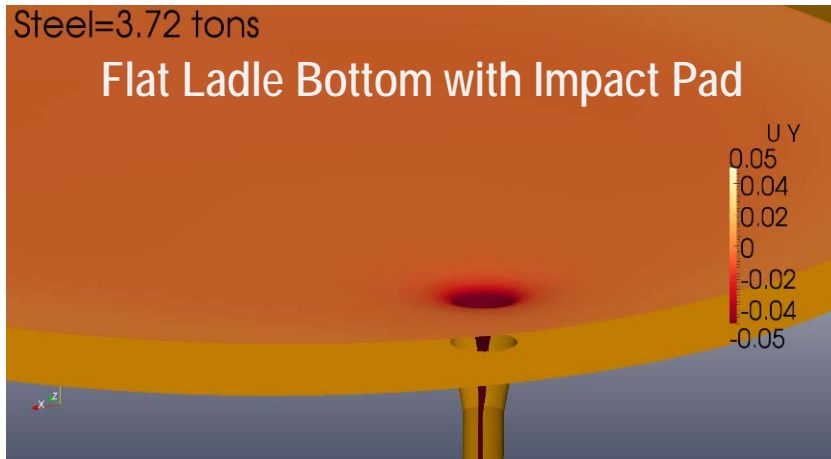

# Advanced Refractories – Products and applications

## Tundish

Refractory Market £/T of Hot Metal = 0.5

### Working Lining

- MgO based wet spray
- MgO based Dry Vibratable

### Permanent Lining

- Bauxite or Mullite based Low Cement Castables
- Cast-in-Situ

### Insulating Layer

- Insulating Bricks/Tiles
- Ceramic Fibre
- Micropore Tiles

### Tundish Furniture – Baffles, Dams & Skimmer

- Bauxite or Mullite based Low Cement Castables
- Precast

### Turbostop

- Bauxite or Magnesia based Low Cement Castables
- Precast

### Nozzle Wellblock

- Bauxite or Mullite based Low Cement Castables
- Precast

### Insulating Tundish Cover

- Combination of Lightweight Castables & Bauxite or Chamotte based Low Cement Castables
- Precast or Cast-in-Situ

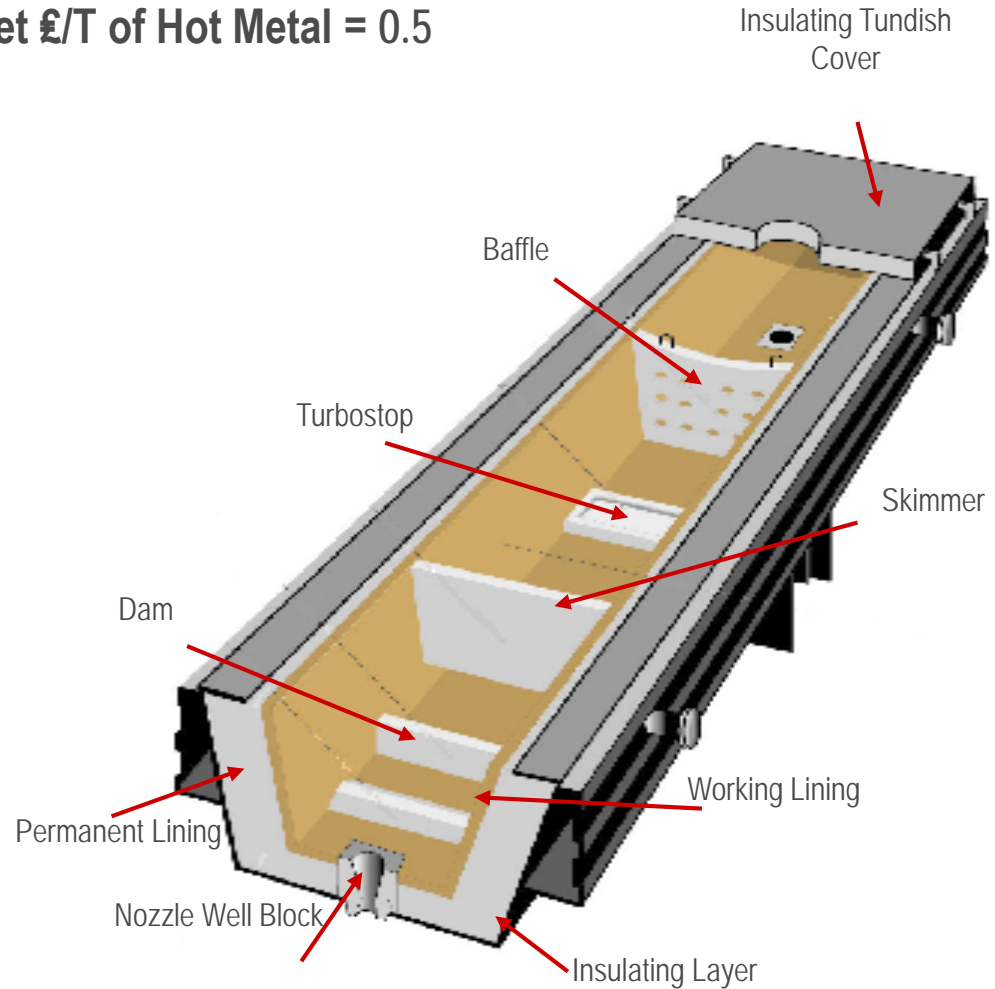

# STEP Technology – Tundish simulation

STEP Technology improves flow through to casting nozzle, whilst reducing steel left in tundish after cast

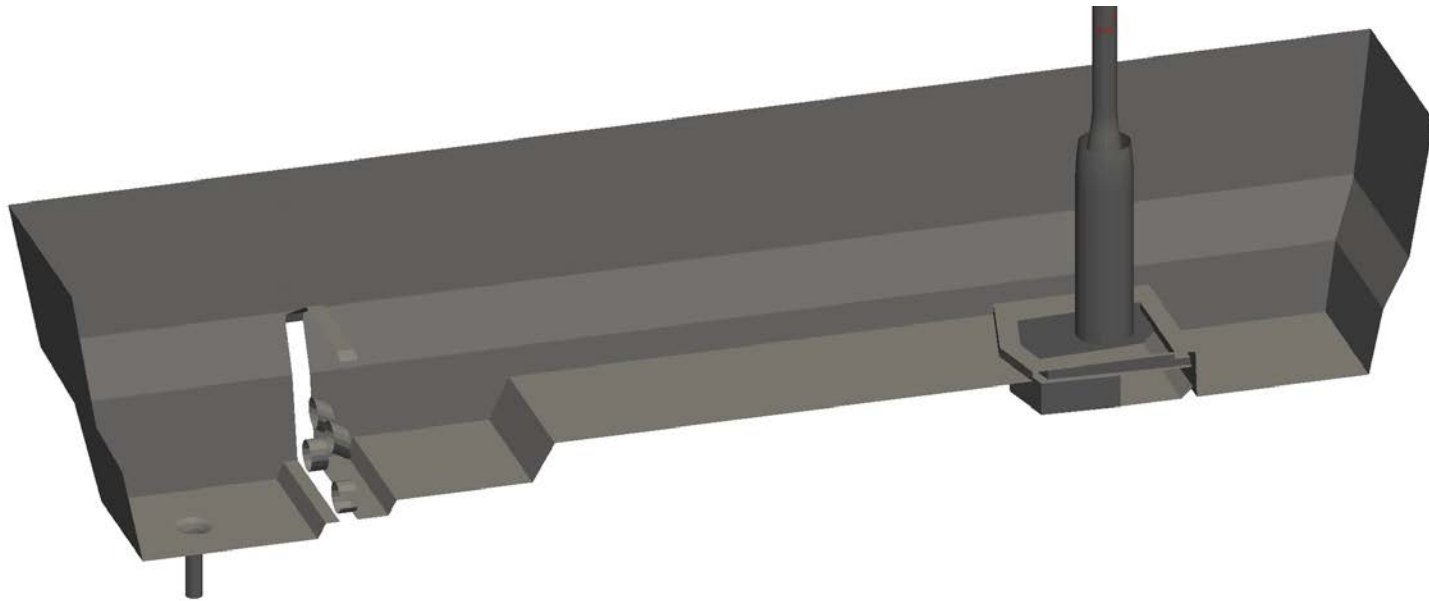

Steel in Tundish: 0.0 ton



# Advanced Refractories – Non-Steel products and applications

## Industries Served

- Metals Producers
  - **Aluminium**
  - Non-Ferrous
  - Ferro-Alloys
- Foundry
- Minerals Processing Industries
  - **Cement**
  - Lime
- Power Generation
- Incineration
- Hydrocarbon Processing Industries

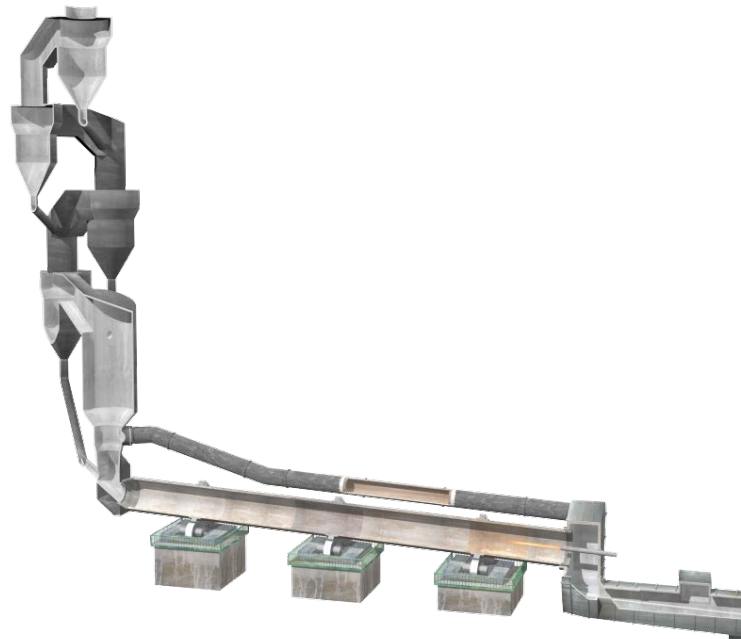
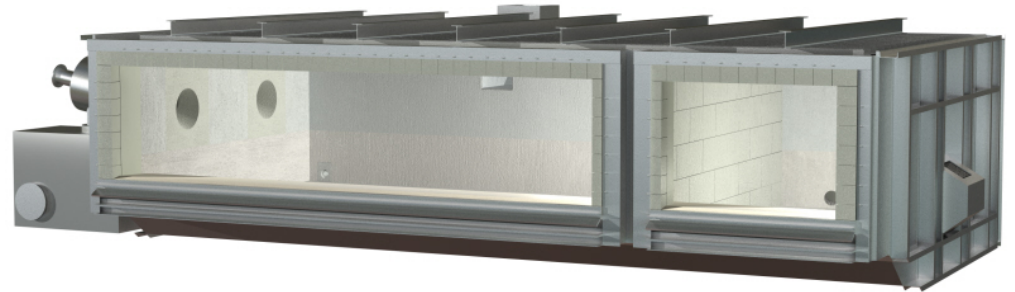

# Advanced Refractories: Manufacturing locations/ regional headcount

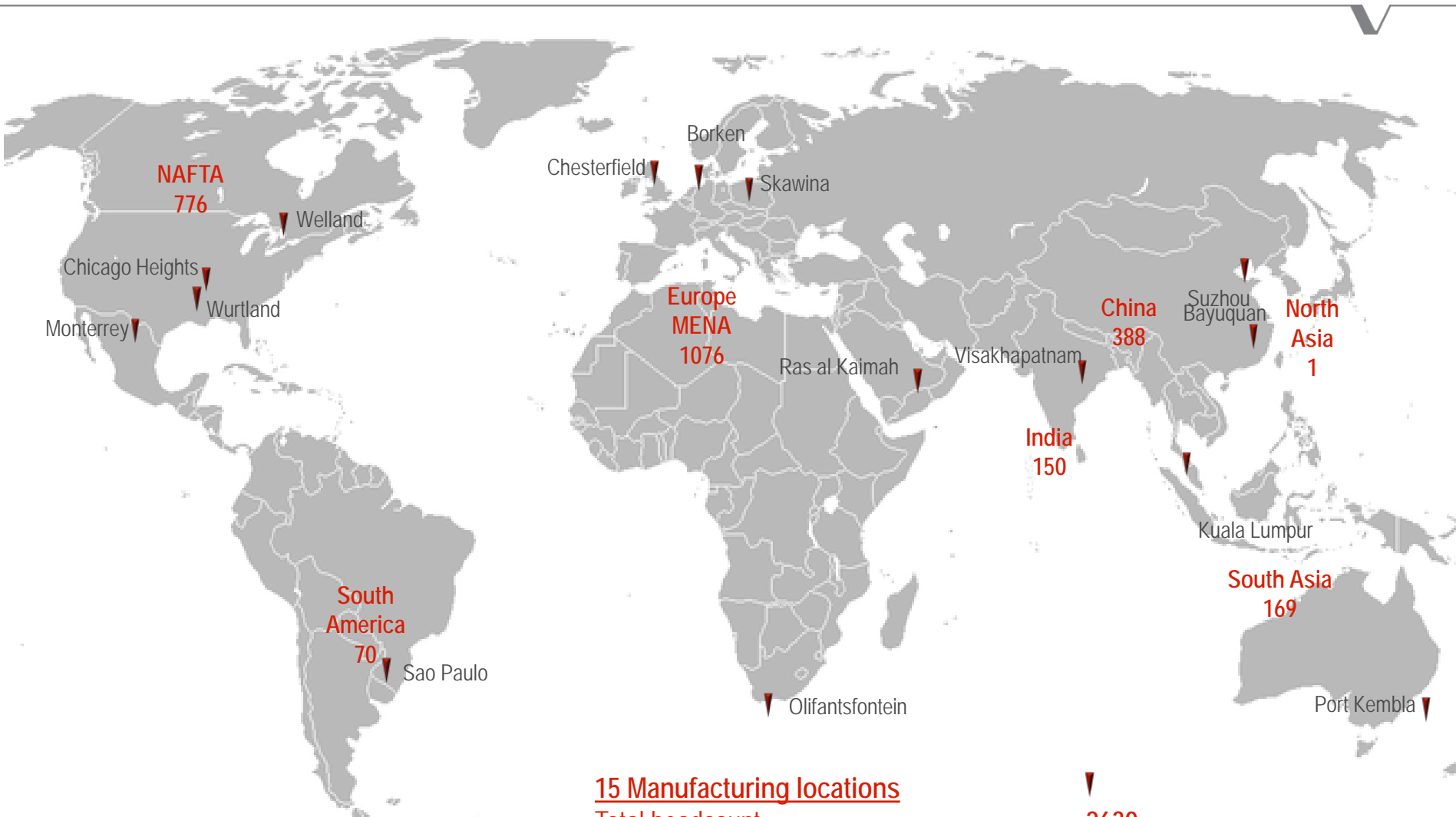

## 15 Manufacturing locations

Total headcount

Resources in developing markets



2630

30%



# Advanced Refractories – Revenue by product line and geography

Distribution of Revenue by PLN in 2014

Distribution of Revenue by market in 2014

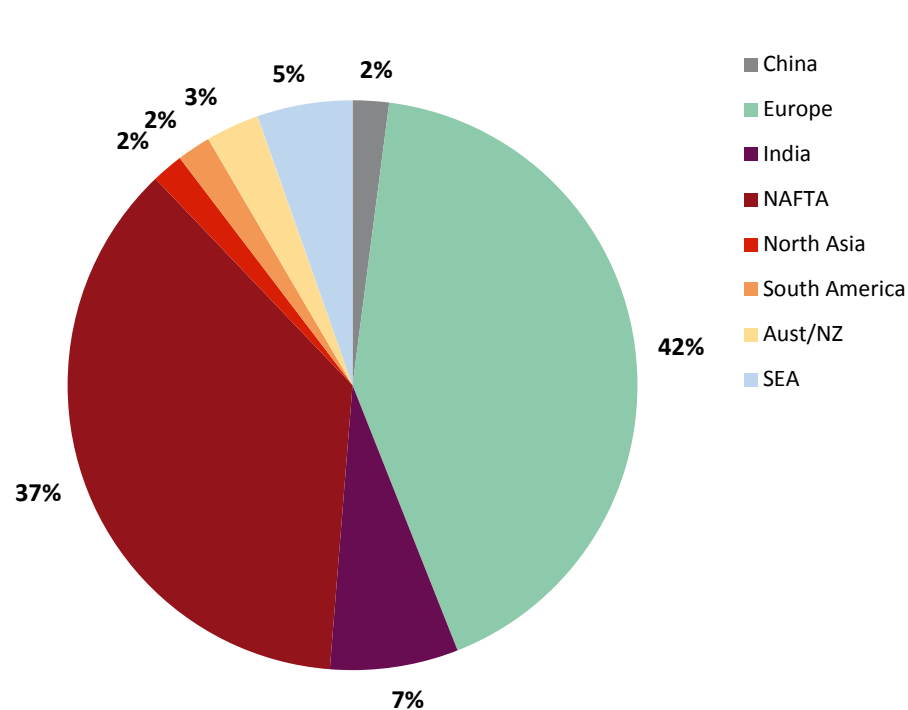
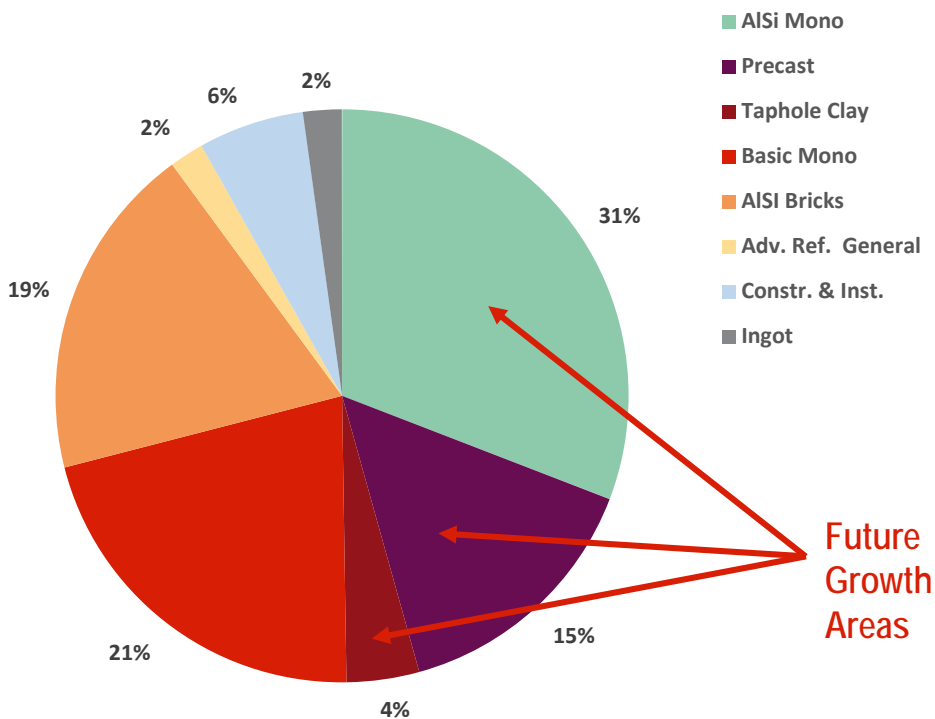

# Sales with top 10 customers have grown 51% since 2008

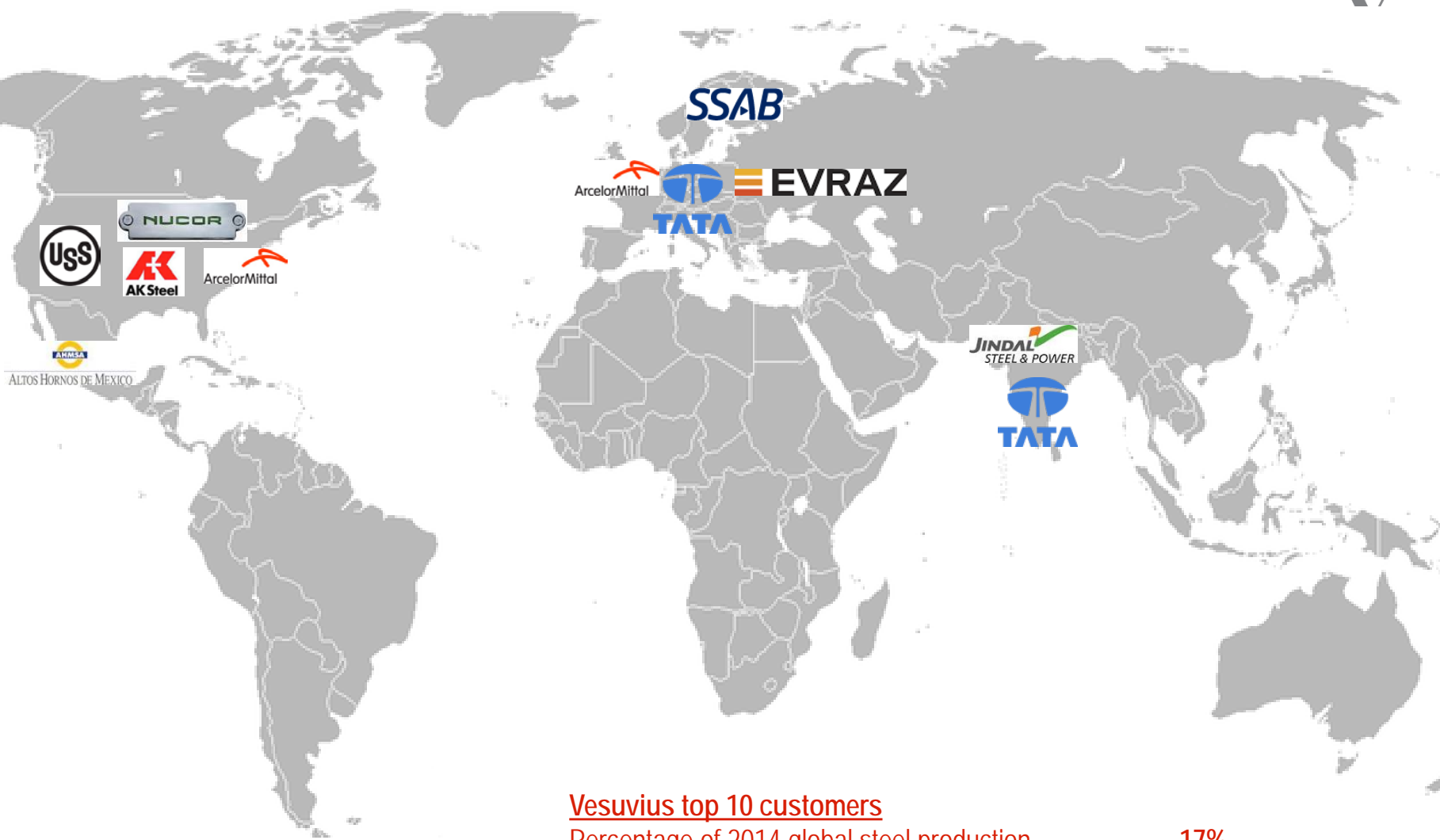

## Vesuvius top 10 customers

Percentage of 2014 global steel production	17%
Percentage of 2014 Advanced Refractory revenue	42%





# Advanced Refractories – Delivering on the strategy

- Maintain technology leadership

New stage gate system to improve innovation process  
Centre of Excellence in Vizag, India  
R&D restructured under one global director

- Increase penetration of value creating solutions

Lavagard BF trough systems for Europe and Nafta  
ELBY in Nafta and Europe  
Alugard in Secondary Alluminium, Nafta  
Smart robotics for tundish in Nafta

- Capture growth in developing markets

Secured first BF trough contract in China  
Market leader in BF trough market share in India  
Tap Hole clay repeat orders in India  
Secondary Aluminium success in Brazil

- Improve cost leadership

Lean manufacturing programme  
Logistics Programme

- Build technical services offering

First fully automated high speed ladle laser refractory monitoring system in a complete TRM contract  
Flow Modelling in Tundish / Ladle

# Maintain technology leadership

- Progress in 2014

- Launched rigorous Stage-Gate® process for managing New Product Innovation
- Restructured R&D under one global director to enhance collaboration across our business
- Completed design plans, for new R&D Centre of Excellence in Vizag, India to be built in 2015 (schematic bottom right)

## Research and Development Center of Excellence in Vizag India

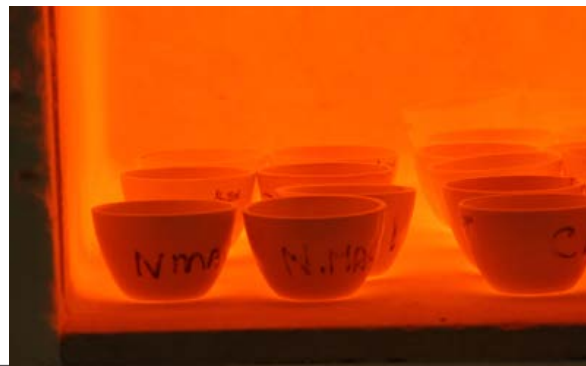

# Increase penetration of value creating solutions

## Developing markets

Development of the Blast Furnace Trough business in India – New entrant to Market Leader in 5 years. Product, Design, Installation & Monitoring to drive value for customer.

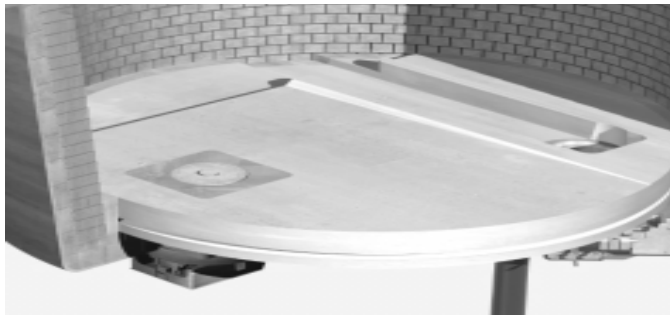
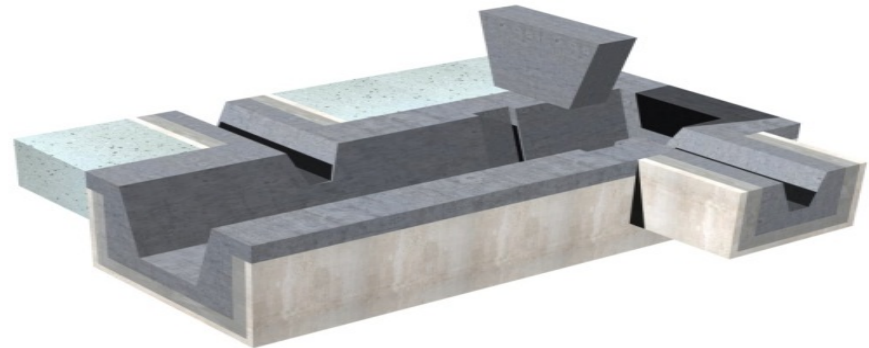

## Value creation in a mature market

Continued penetration of ELBY™ ladle bottom in NAFTA and Europe based upon prime steel yield improvement.

# Build Technical Services offering

- Installation of the first fully automated high speed ladle laser refractory monitoring system in a complete Total Refractory Management Solution contract
- ACCESS Model (Advanced Control for Cost and Energy Savings by Simulation) developed tool to monitor the thermal profile of the ladle providing improved steel quality, improved energy use and optimised ladle lining design

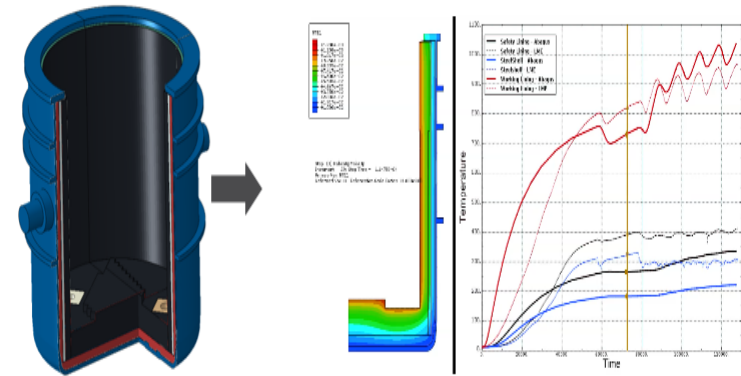

# Steel Production and Advanced Refractories Sales (2014)

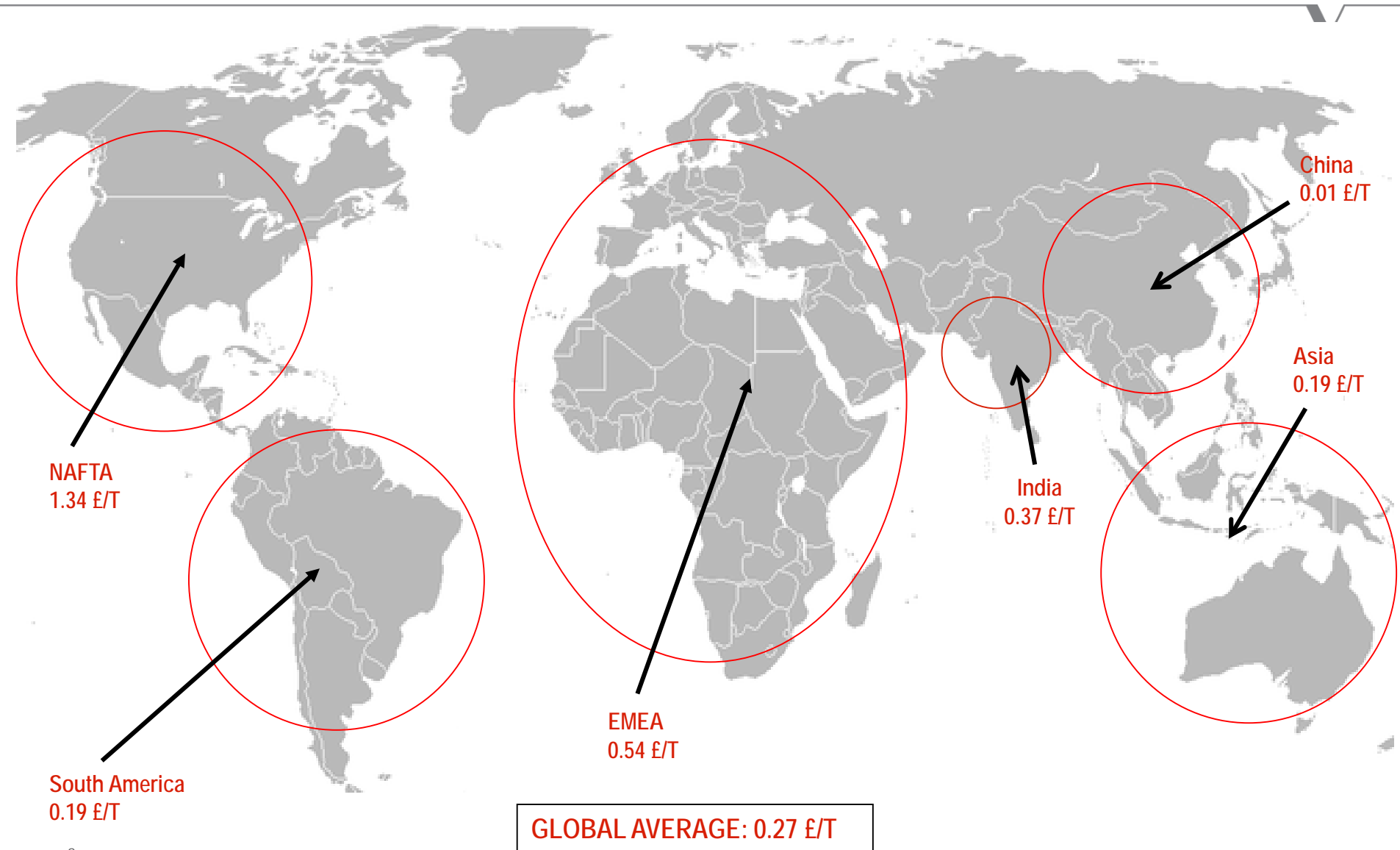

Source:

# Steel Advanced Refractories

- Drive growth in select markets and product categories
  - **Markets:** India / China / MENA / South America
  - **Products:** Tundish / ladle / iron making / aluminium
  - **Services:** Technical Services / Modelling
  - NPI to be more robust and targeted
  - Segment and differentiate



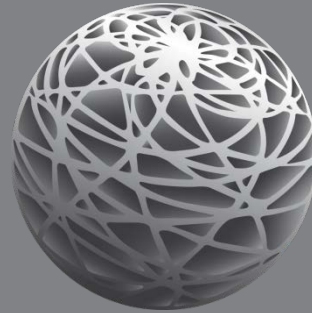

A GLOBAL LEADER IN METAL FLOW ENGINEERING

## Steel Division: Flow Control

Chris Abbott

President, Flow Control

VESUVIUS PLC

# Steel Flow Control

---

- Main products and markets
- Strategy and growth opportunities in Flow Control
- The Flow Control business model
- Technical Services within Flow Control





# Steel Flow Control: Main products and markets

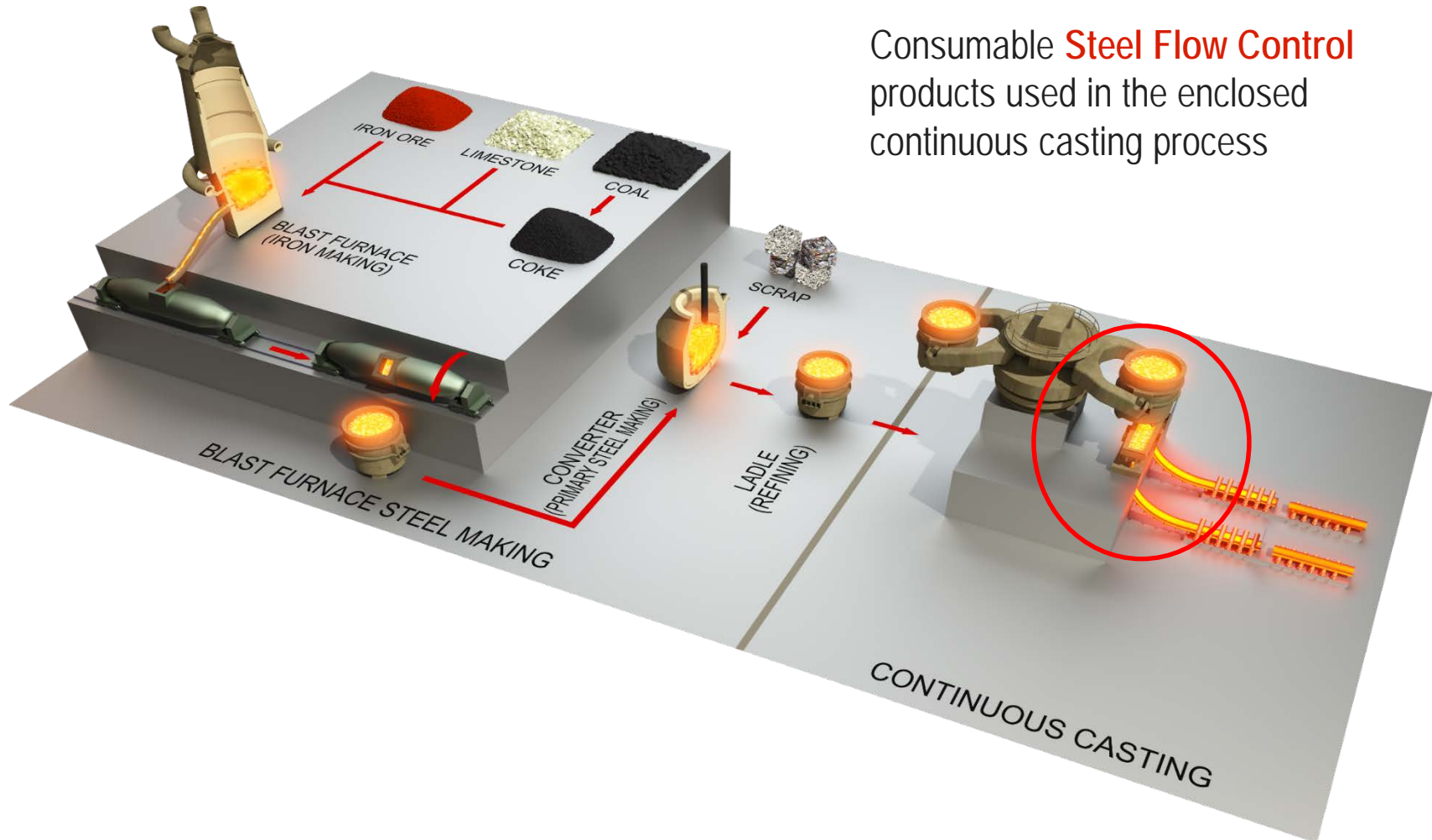

Consumable **Steel Flow Control** products used in the enclosed continuous casting process

# Steel Flow Control: Main products and markets

- A world leader in the supply of consumable **Steel Flow Control** products used in the enclosed continuous casting process

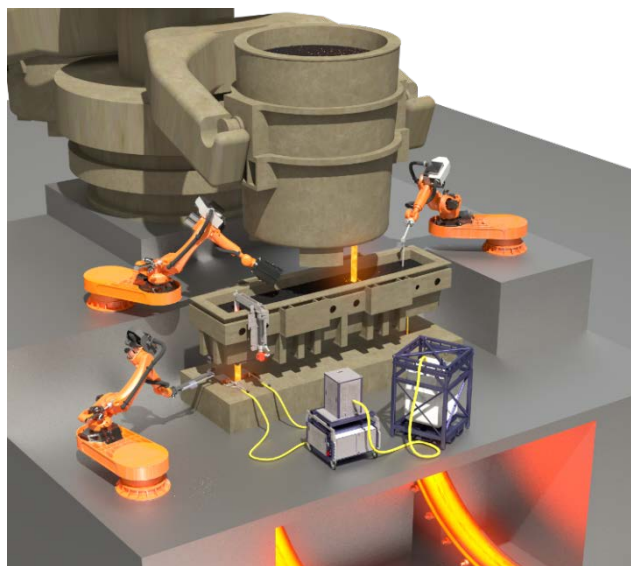

- Consumables average life 6 – 8 hours
- Vesuvius differentiation brings reliability & functionality to increase our customers' profits

## Flow Control division revenue by operating location

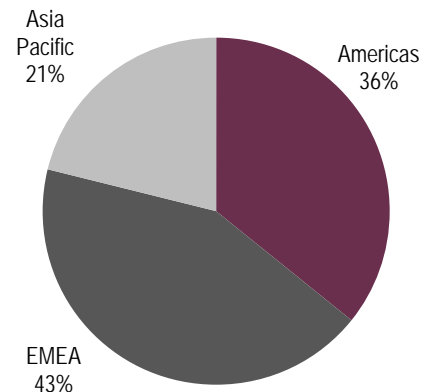

Source Vesuvius breakdown of 2014 Reported Revenues

Well balanced presence in all major geographical areas

- Vesuvius is the only truly global player in Flow Control
- Asia Pacific major volume growth potential
- Europe, NAFTA & Korea as laboratories for innovation



A global leader for steel flow control consumable ceramics

# Sales with top 10 customers have grown 25% since 2008

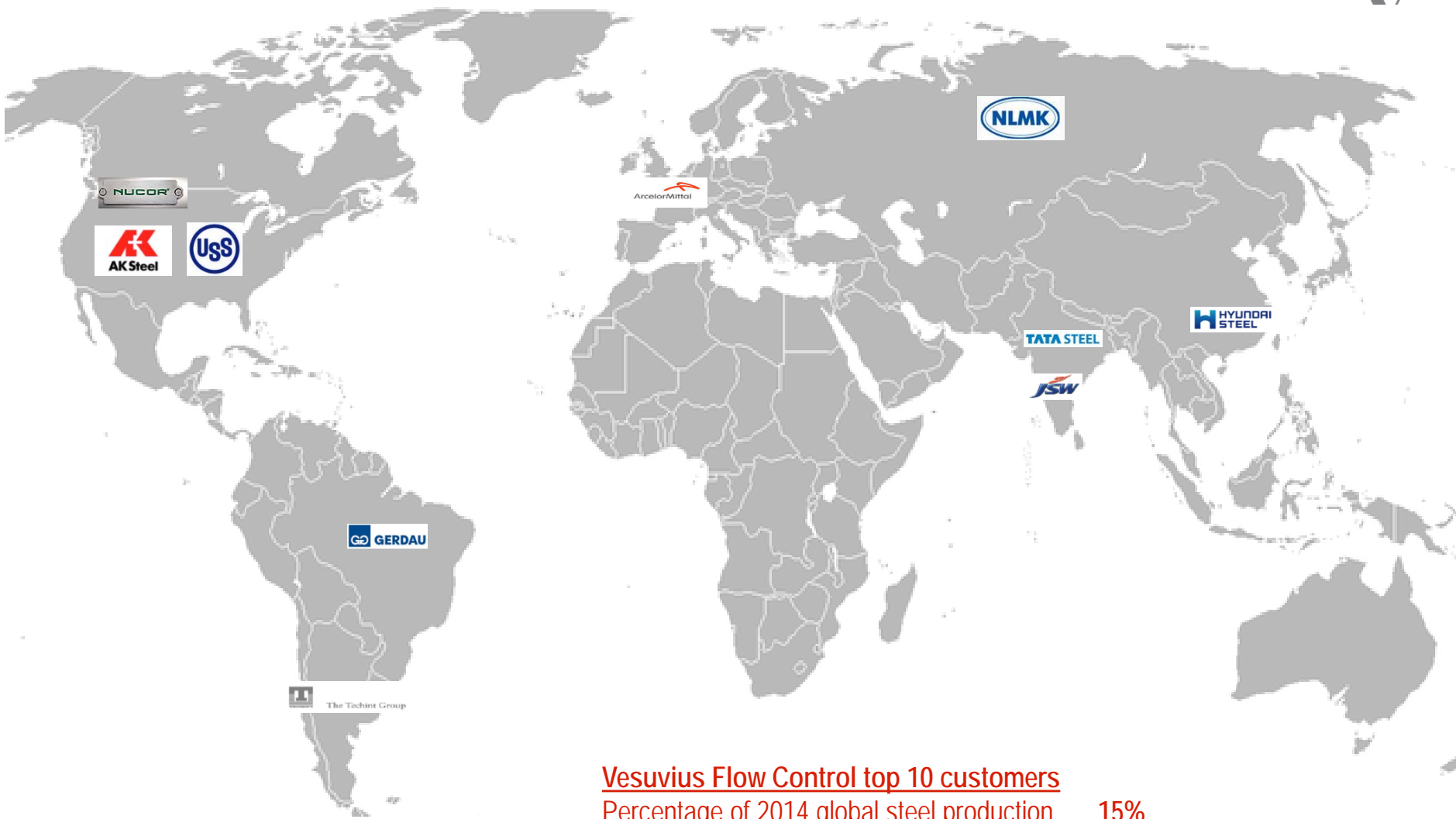

## Vesuvius Flow Control top 10 customers

Percentage of 2014 global steel production	15%
Percentage of 2014 Flow Control revenue	44%



# Steel Flow Control: Sales/tonne have grown 32% since 2009

Flow Control sales continue to outperform the underlying Market

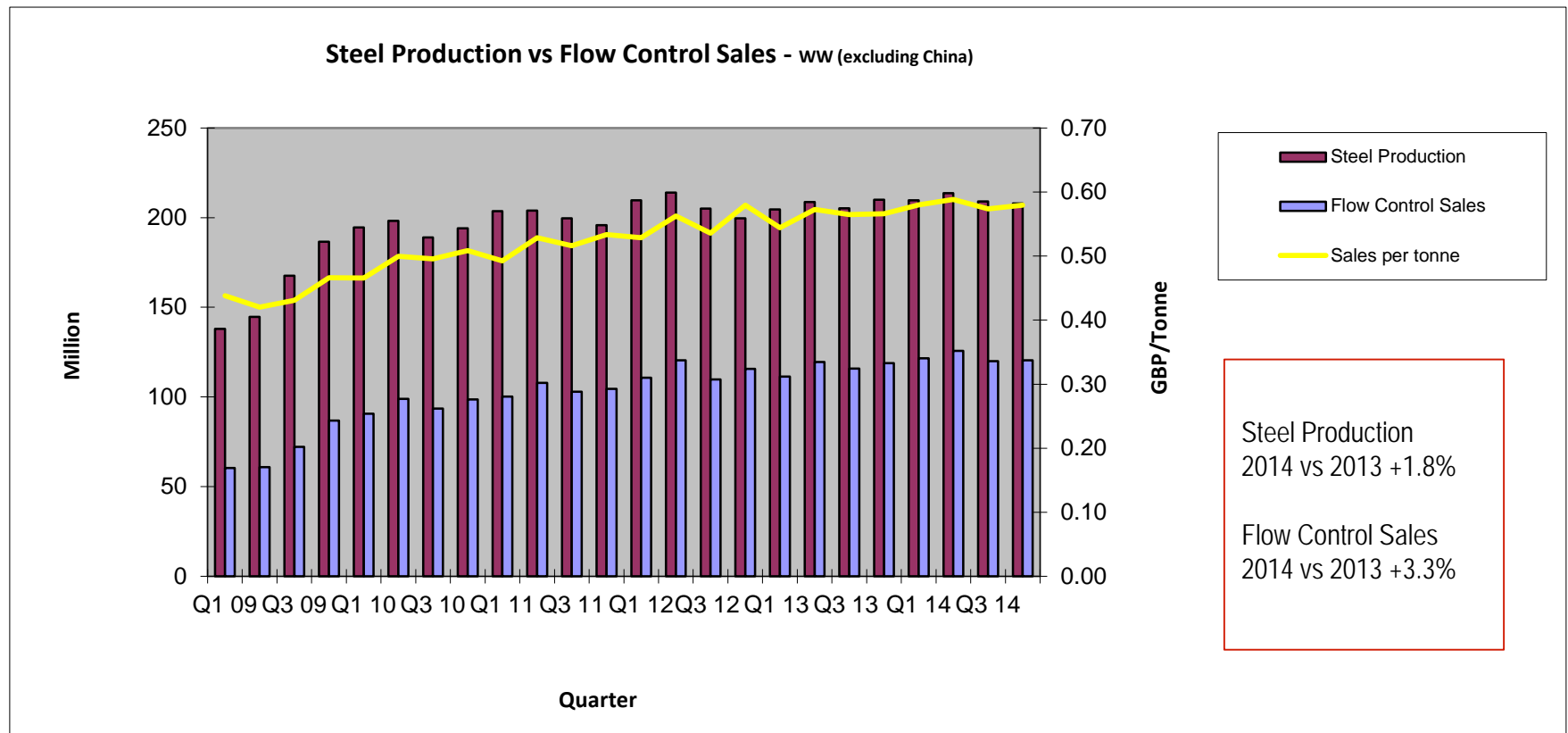

# Steel Flow Control: Delivering on the strategy

- Maintain technology leadership

New location selected in Pittsburgh for R&D Centre  
New Product Introduction process improved  
Enhanced Mechatronic capability in Ghlin

- Increase penetration of value creating solutions

Success of robotics handling operations  
Patented new generation tube changer  
Integration of recently acquired Companies technologies in RCT Offering  
Continue to add complimentary product lines & services where we are strong

- Capture growth in developing markets

Invest in countries where steel production is growing  
Capacity increases to capture growth in China & India  
Viso mix plant commissioned in Brazil  
Upgraded facility in Istanbul

- Improve cost leadership

Lean manufacturing programme  
Logistics Programme

- Build technical services offering

Creation of Solutions Group  
Introduction of PDM300 Flux Feeder  
Introduction of XMAT Mould Tool Audit  
Introduction of SMART Refractories

# Steel Flow Control: Growth opportunities

## New steel capacity

- Greenfield plants in S America, India, SE Asia, Mexico, USA, Vietnam
- Increases in Korea & Brazil
- Revamping projects in China

## Technology developments

- Safety, Quality and Cost requirements will increasingly influence automation & robotics and the need for improved data capture

## Challenging market demands

- Overall emphasis on 'clean' steel
- Increase production of higher quality steel grades
- Technology developments in Automotive market sector will continue to drive technology developments in steel and the need for innovative refractory solutions

## Technology advice

- Technical & advisory services to steelmaking industry through Solutions Group
- Leading edge modelling and flow simulation
- Process data analysis



# Substantial opportunity for penetration exits

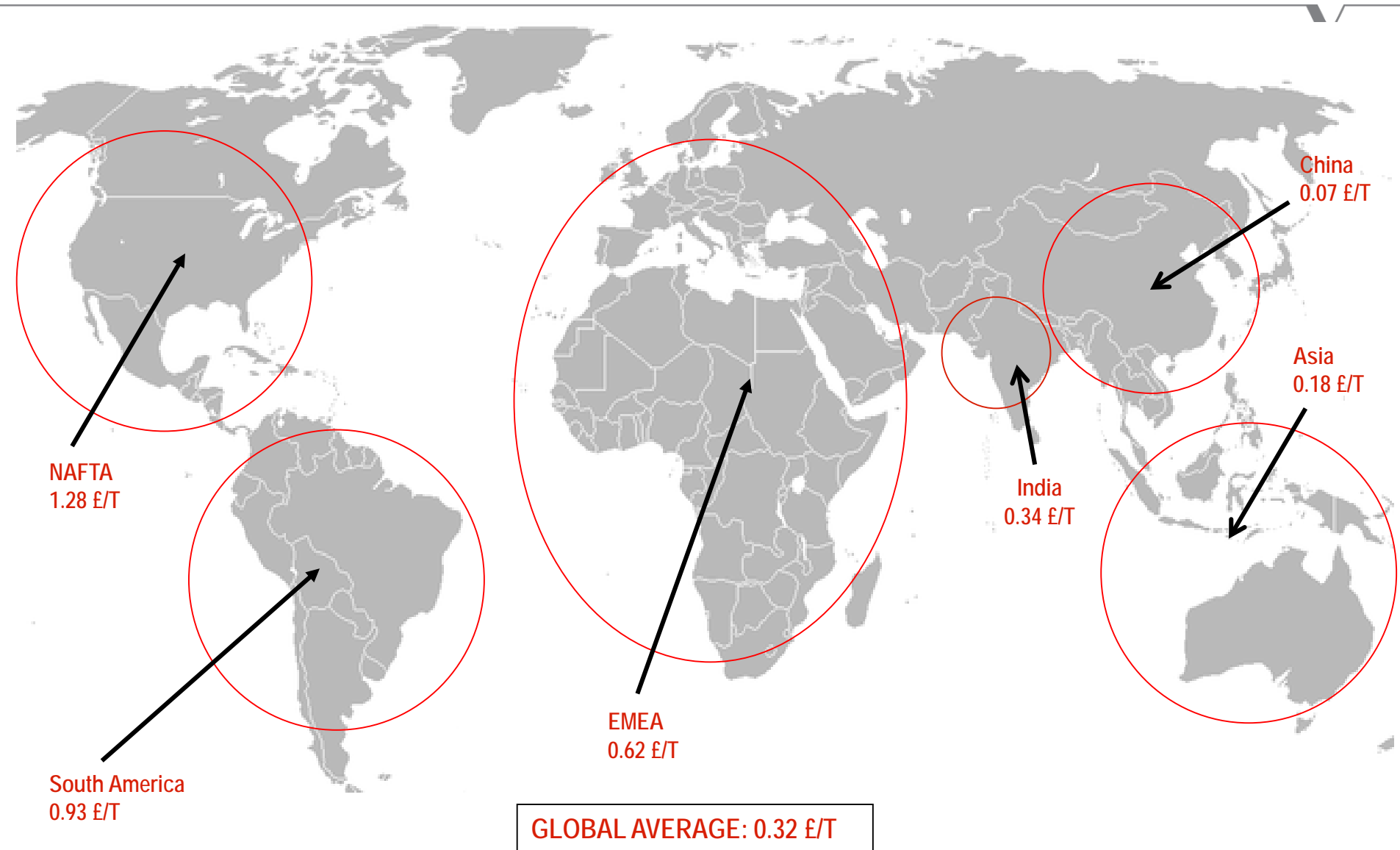

# VESUVIUS "Solutions through Technology" approach

## SERVICE

Instruments



FC Systems

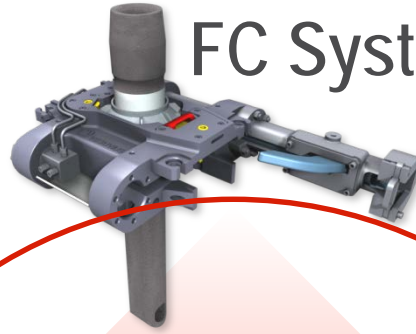

Data capture

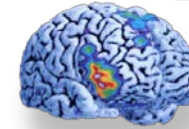

Value added



Modelling &

Design

Solutions



Handling

Materials

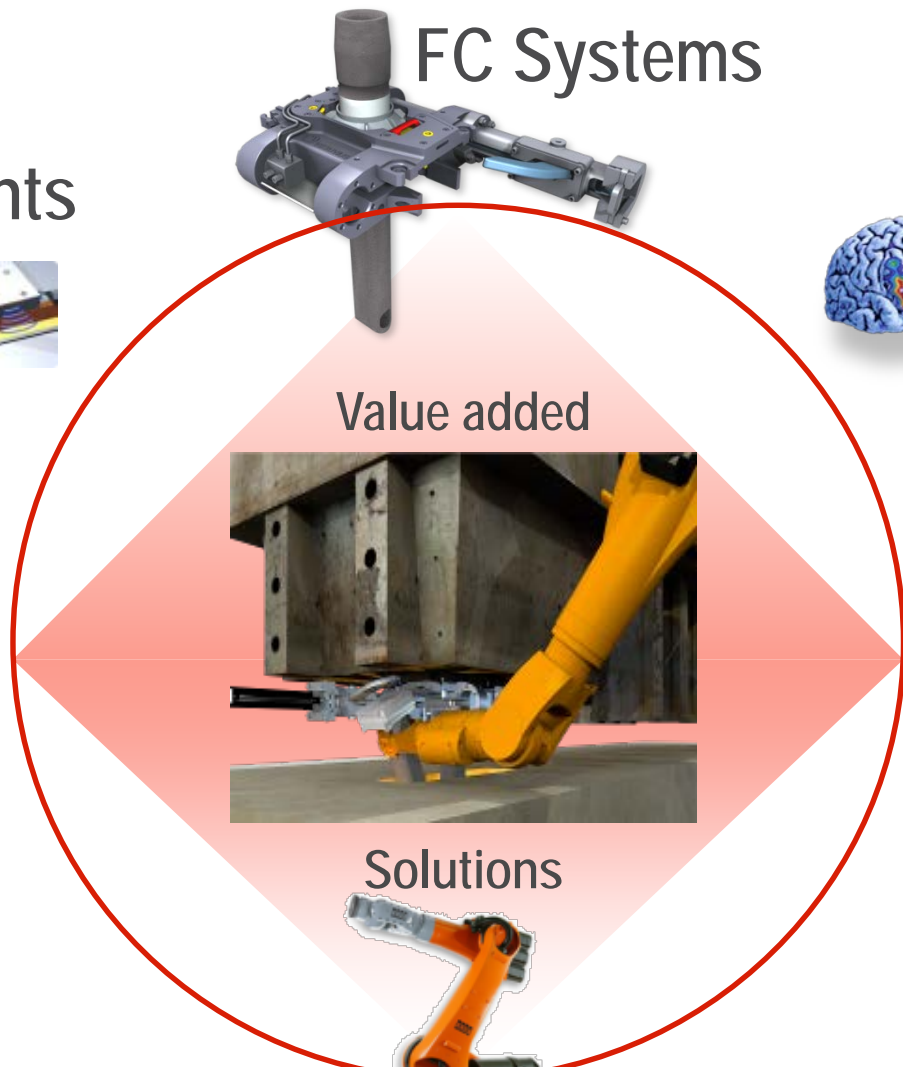



# Steel Flow Control : Robotic Casting Technology

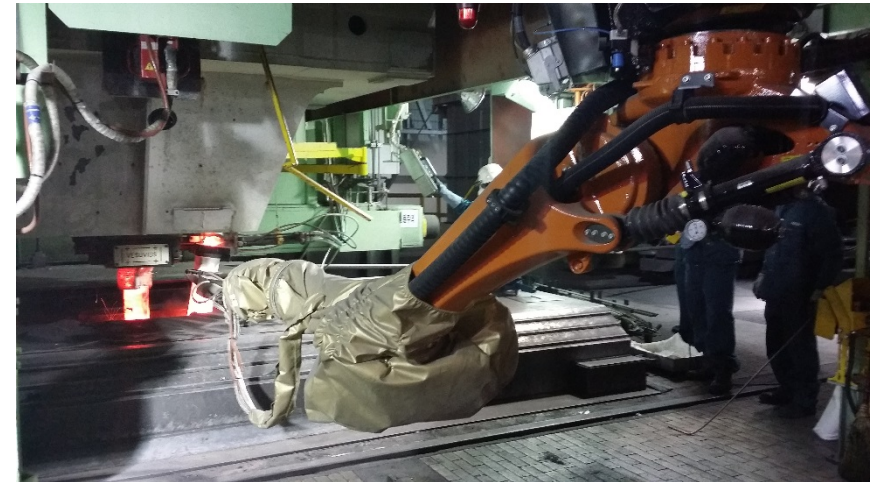

# Steel Flow Control : Robotic Casting Technology



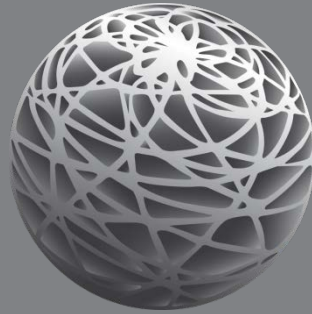

A GLOBAL LEADER IN METAL FLOW ENGINEERING

## Technical Services in Flow Control

Chris Abbott  
President

VESUVIUS PLC

# Technical Services in Flow Control helps improve our Customer Business

- Combining consumables and equipment enables real time capture of process data allowing our customers to make informed decisions to:
  - Adjust process parameters
  - Improve consistency
  - Improve quality
  - Improve yield
  - Save energy
  - Reduce cost
- Flow Control has the technology and commercial capability to leverage its market position to support the development of Technical Services



# Steel Flow Control: Smart Mould Flux Feeder



Innovative equipment allows us to sell not only consumable material but replaces dangerous manual flux addition and provides a reliable real time process monitoring and facilitates a new pricing model

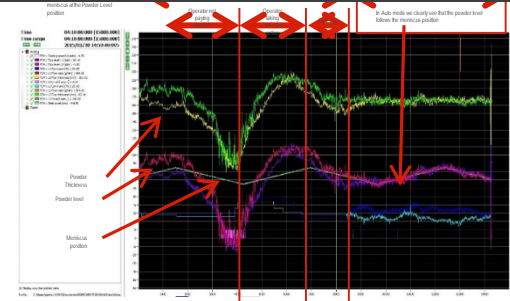
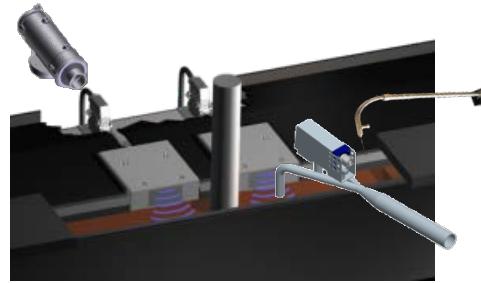
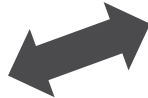

Flux thickness and quantity tracking

Mould instruments

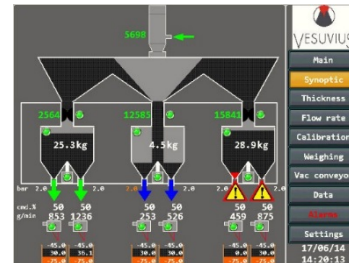
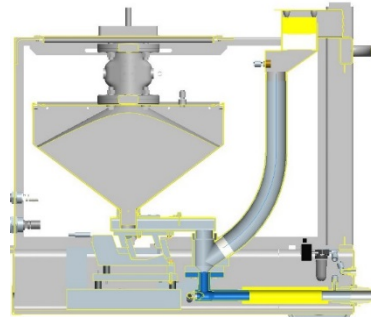

Feeder instruments

Flux quantity tracking



IR monitoring

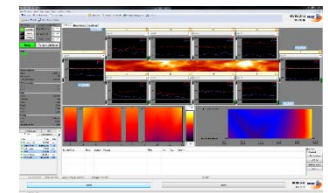

Break out prevention



# Steel Flow Control: Smart Refractory



Smart Refractory allows us to combine refractory, instruments and equipment to provide a complete monitoring solution

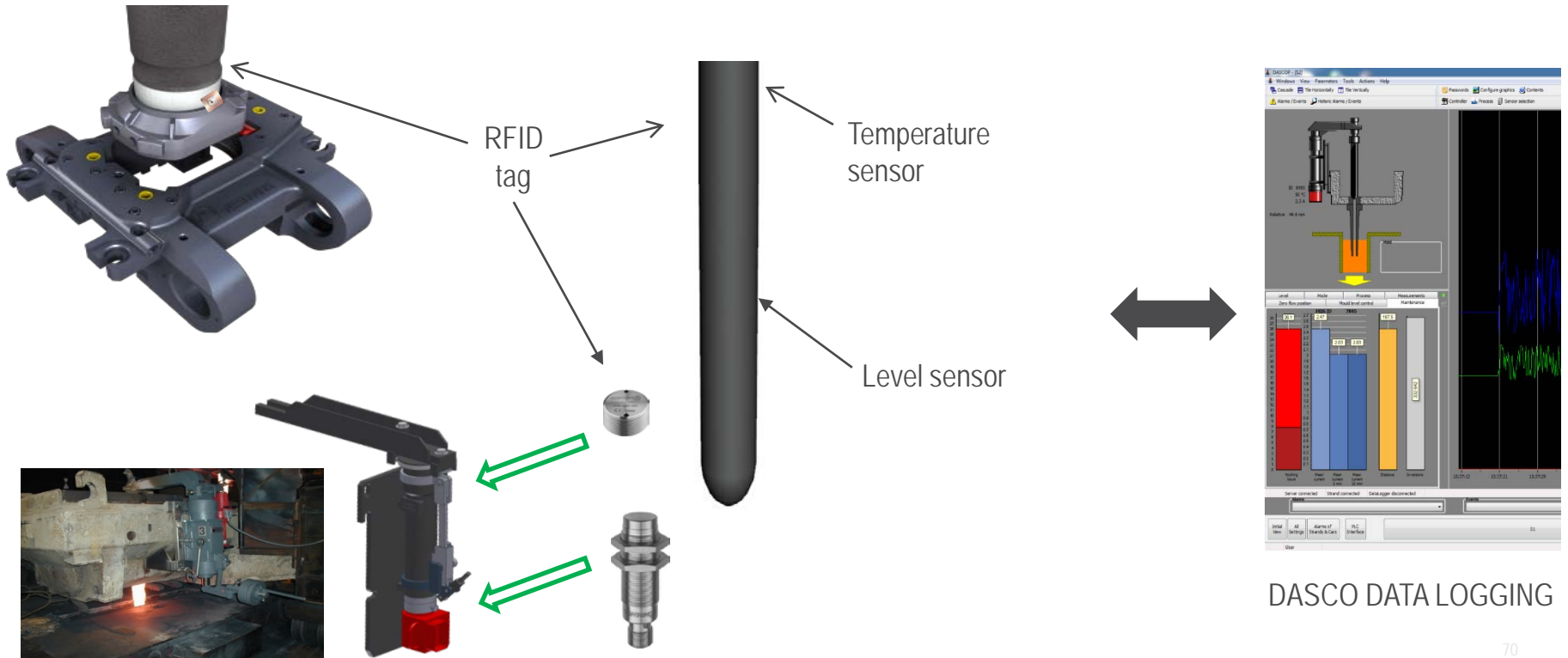

# Steel Flow Control in Summary

- Flow Control still has significant opportunities to grow
- The Flow Control business model of 'Solutions through Technology' will enable us to take advantage of these opportunities, allowing us to continue to grow ahead of the underlying market
- Combining consumables and equipment enables real time capture of process data allowing our customers to make more informed decisions to improve consistency, quality and cost.
- Flow Control has the technology and commercial capability to leverage its market position to support the development of Technical Services



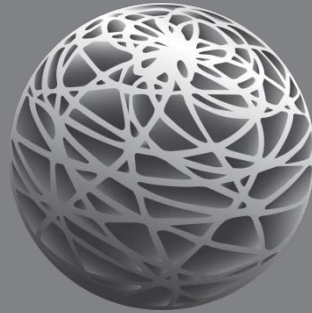

A GLOBAL LEADER IN METAL FLOW ENGINEERING

## Foundry Division

Glenn Cowie  
President, Foundry

VESUVIUS PLC



# Foundry

- What is a Foundry?
- Who are our customers?
- What they produce
- Markets we serve
- Who are we?
- Case Studies
- Competitive advantage
- Growth Potential

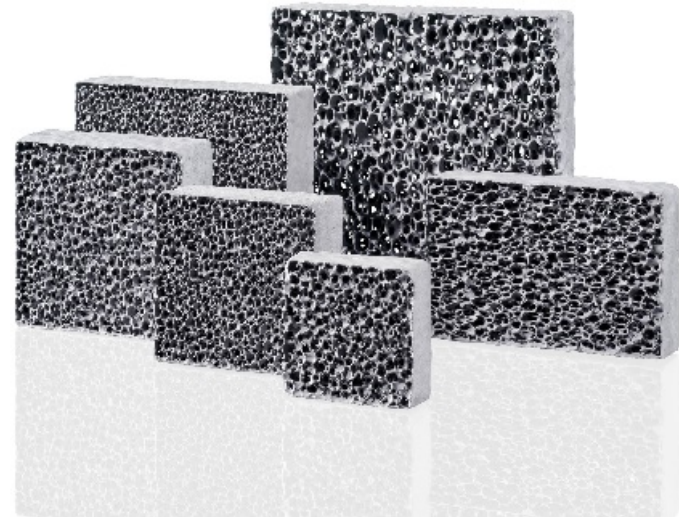

# Customer base



Mercedes-Benz



HONDA



# Video

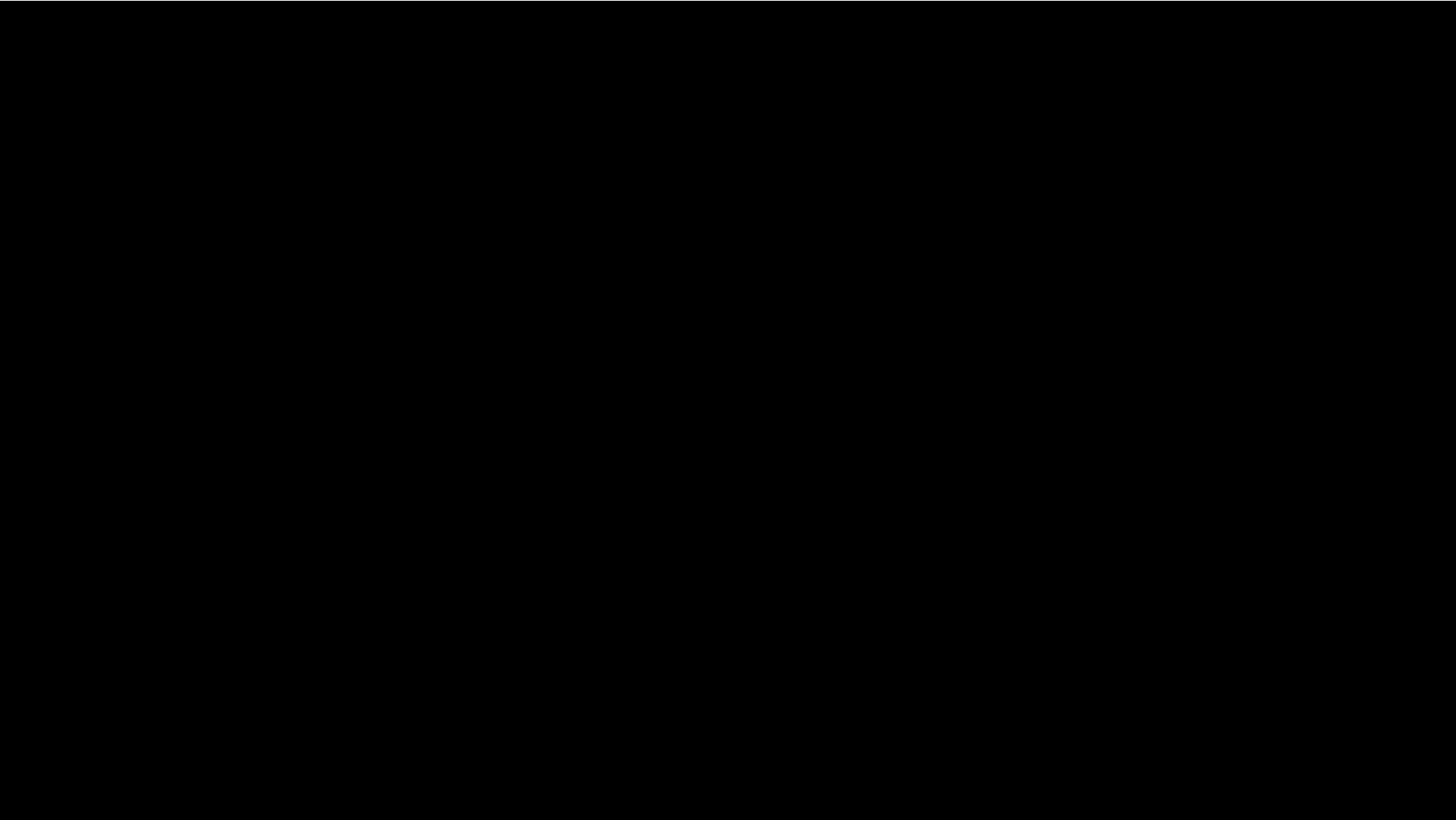

# What do our customers do?

---

- Iron
  - Grey or Ductile
- Steel
- Non ferrous
  - Aluminium
  - Copper Based
  - Zinc



# Global casting end-user

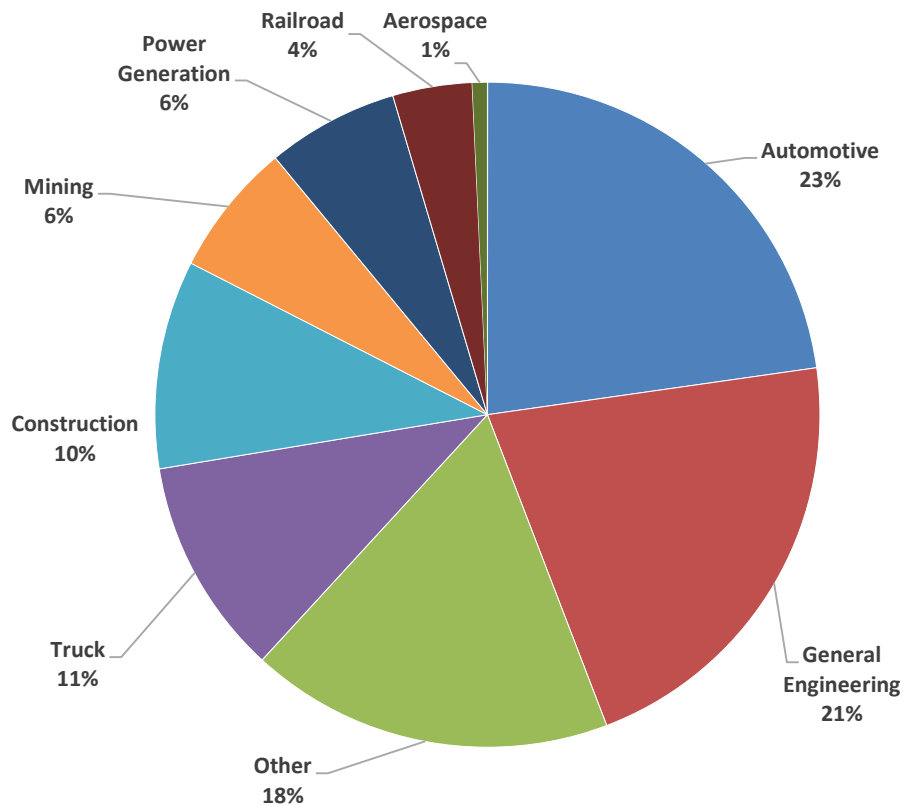

# What they do – Grey Iron, Ductile Iron, Steel

Grey

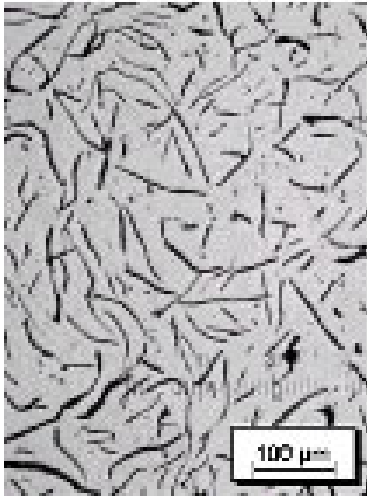

CGI

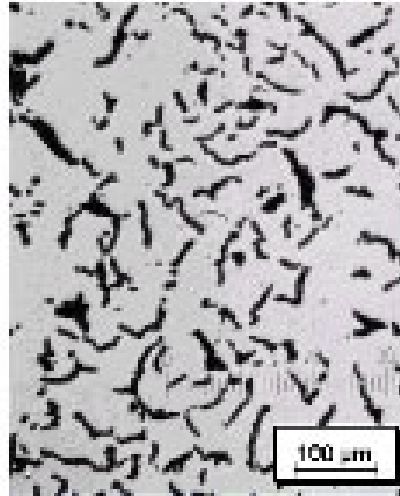

Ductile

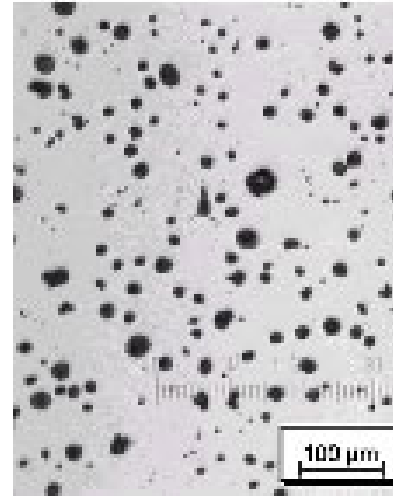

Iron

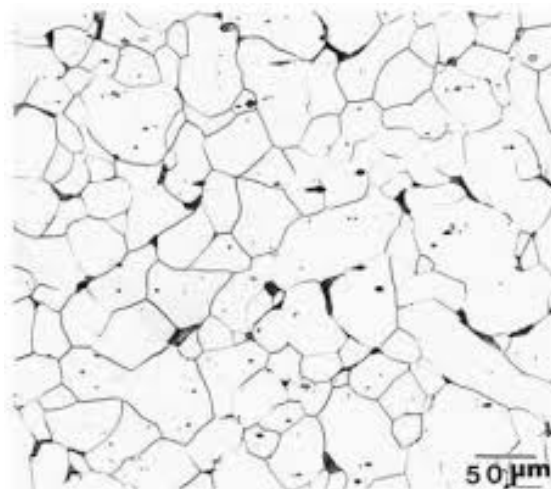

Low-carbon AISI/SAE 1010 Steel

Steel



# What they do – Very small components, all alloys

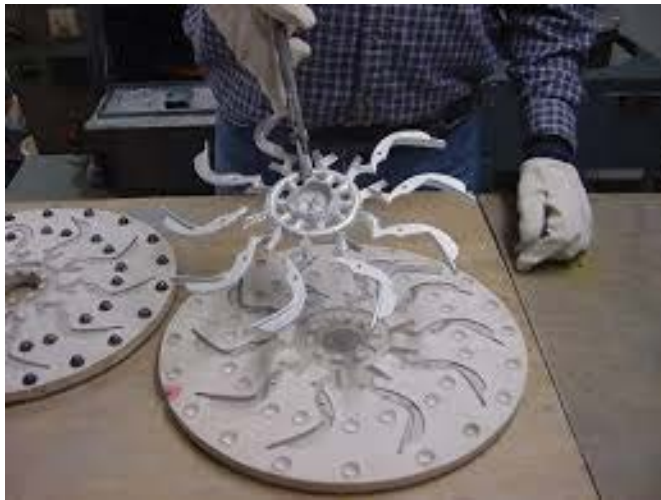

Pattern Tree    Shell-Making    Investment Casting    Casting



# What they do – Non Ferrous

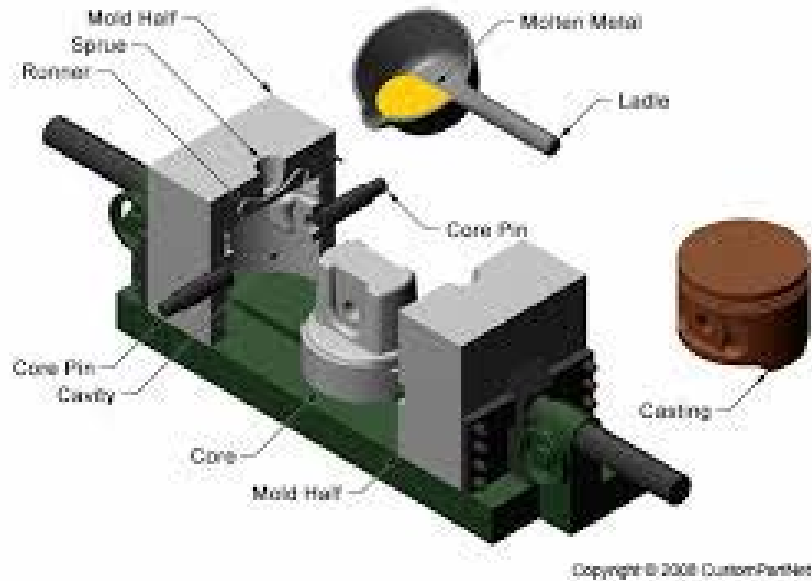

Gravity Die casting



Low Pressure automotive rim





# What they do – Iron



# What they do – Steel



# Foundry: Manufacturing locations, regional headcount and turnover

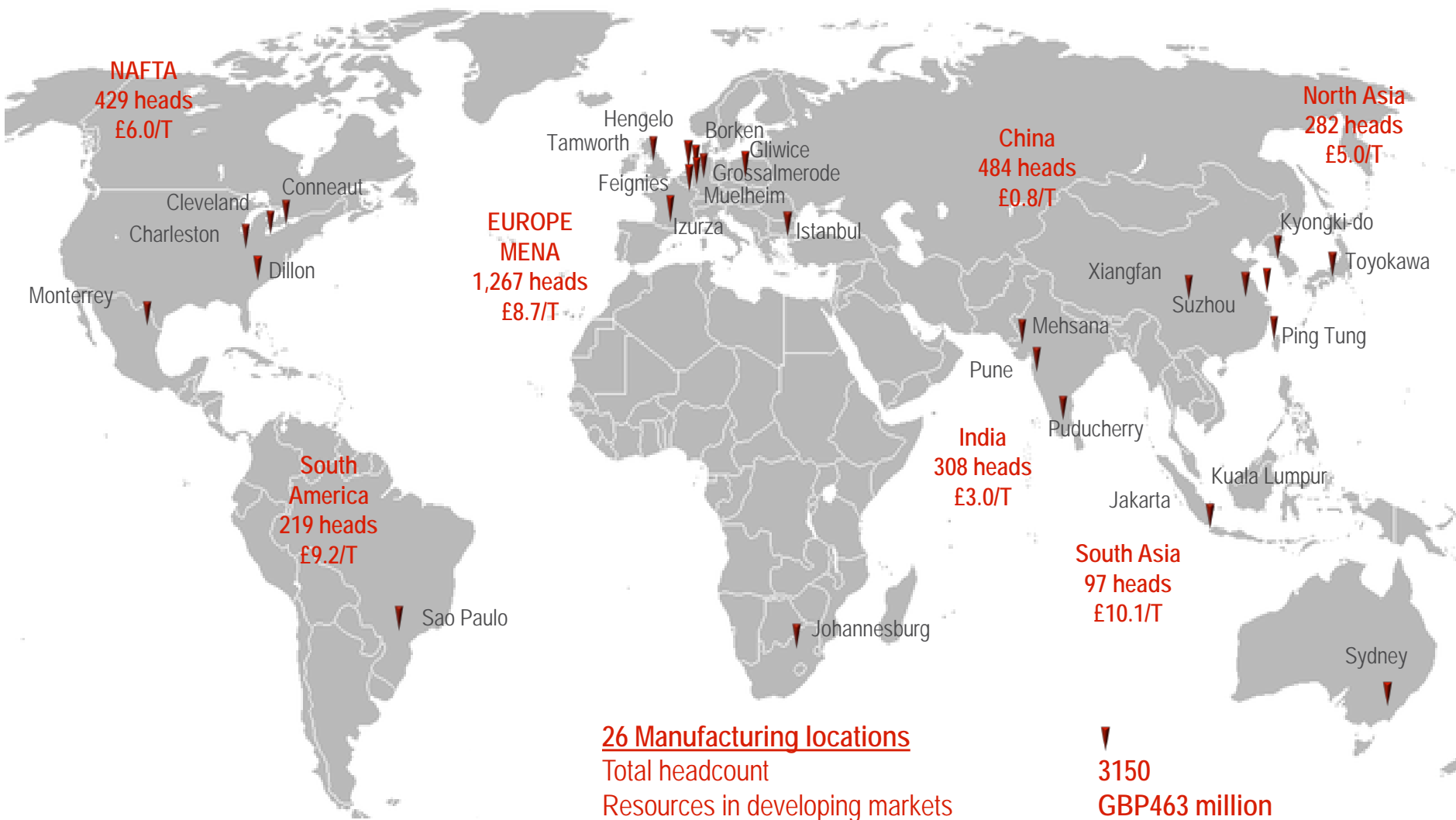

# What we do – Make our customers' business more profitable

- Segmentation
- Market Creation
- Technical Services
- Simulation
- Reduce Customers' Costs
  - Machining
  - Scrap
  - Moulding efficiency
  - Energy consumption
  - Safety
  - Yield

Typical defects we can help eliminate for our customers:

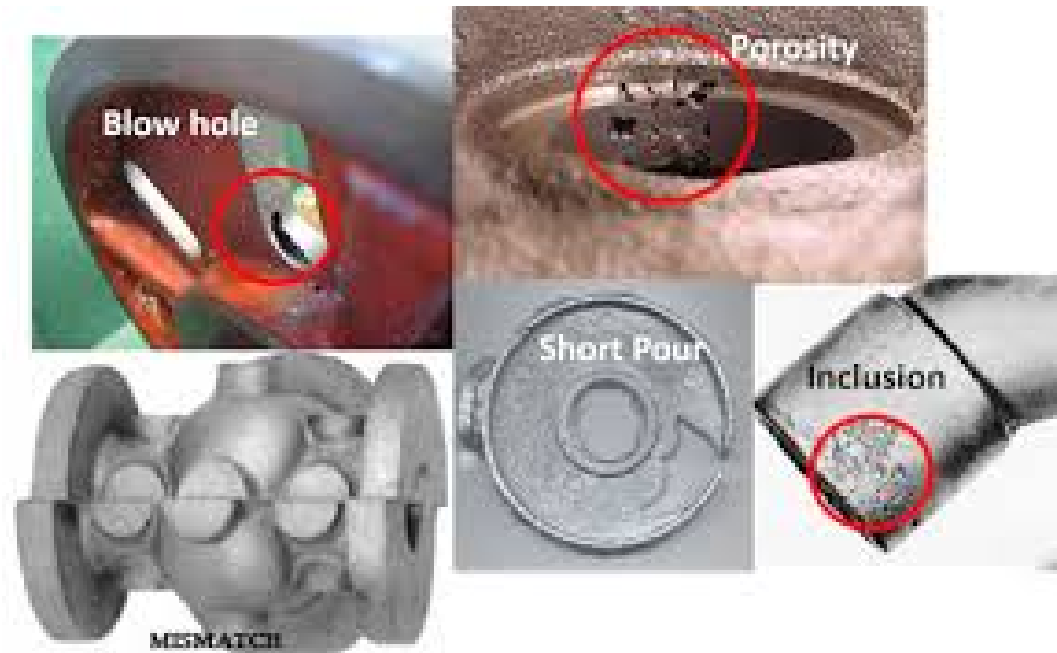

# Aluminium transfer ladle



Refractory ladle: Before



Refractory ladle: After Insural ATL 600



# INSURAL ATL vs Castable Lining: Heat loss



## Thermal Imaging

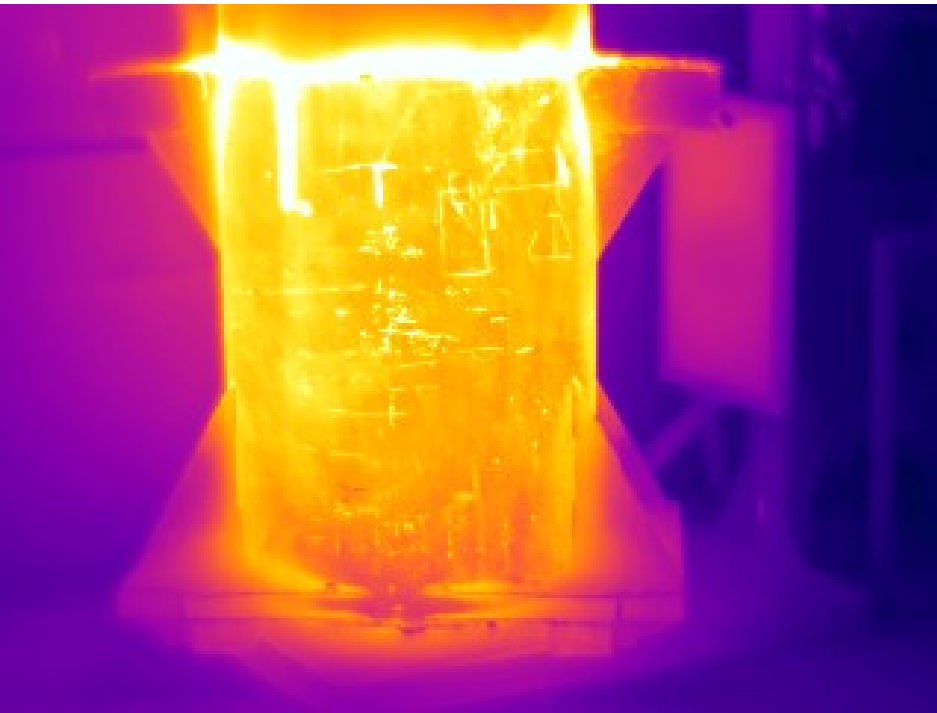

Non-Insural [refractory] ladle

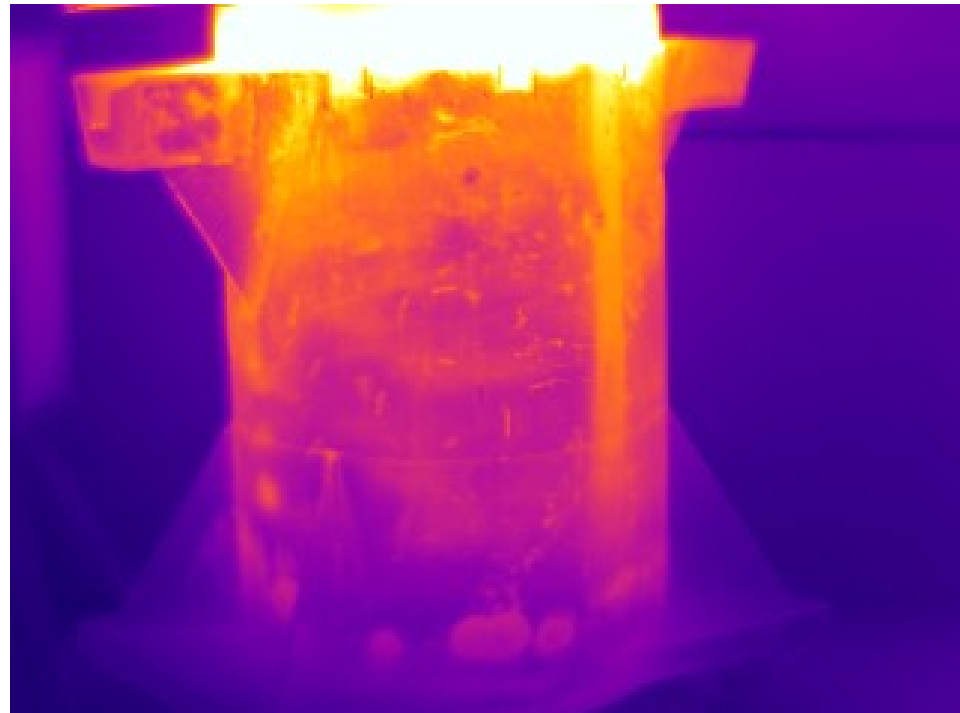

Insural ATL 600 ladle



# Running and Filtering large Iron casting – Cleanliness and yield



# Finished casting

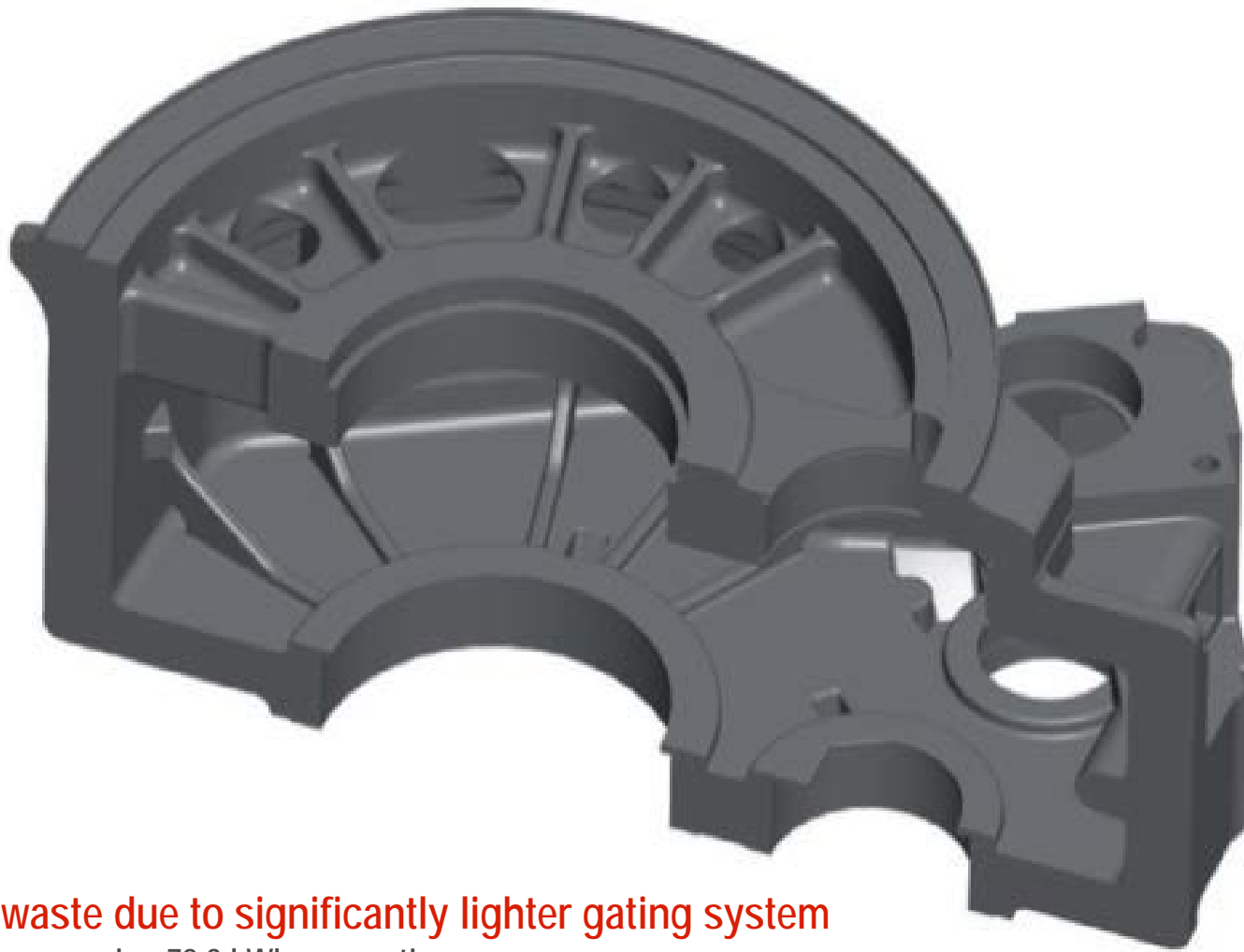

## Less waste due to significantly lighter gating system

- Energy saving 72.3 kWh per casting
- Weight reduction 38.4 kg per casting





# Front Hub Disc Casting – NISSAN Foundry Spain

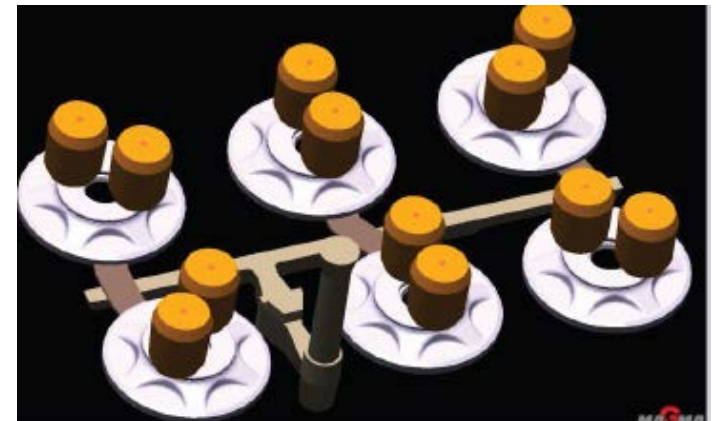
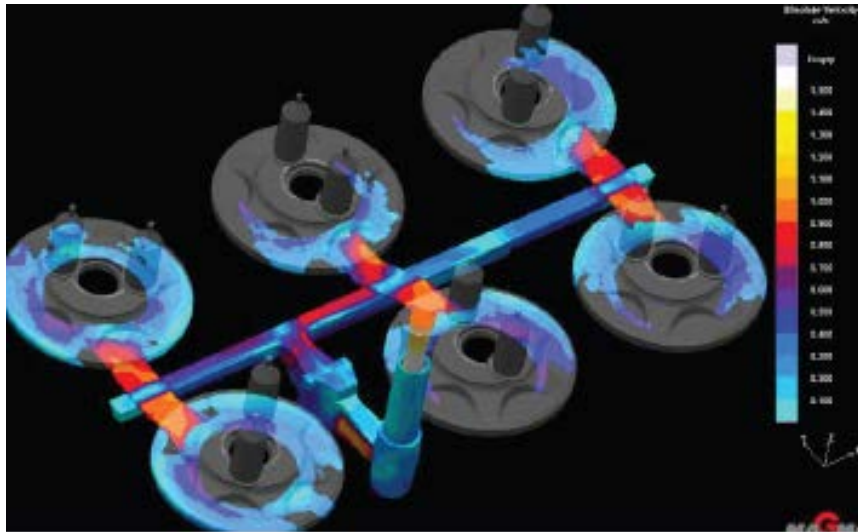
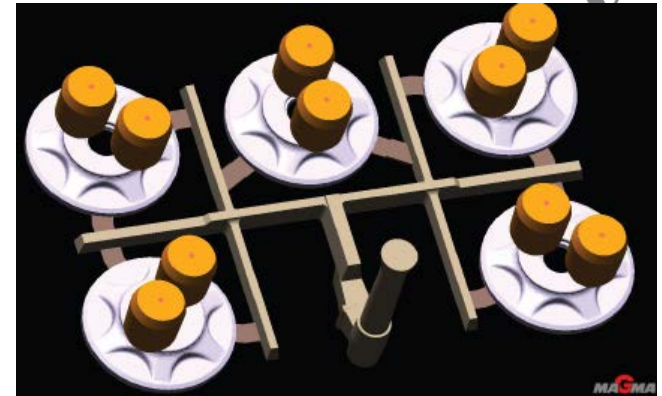
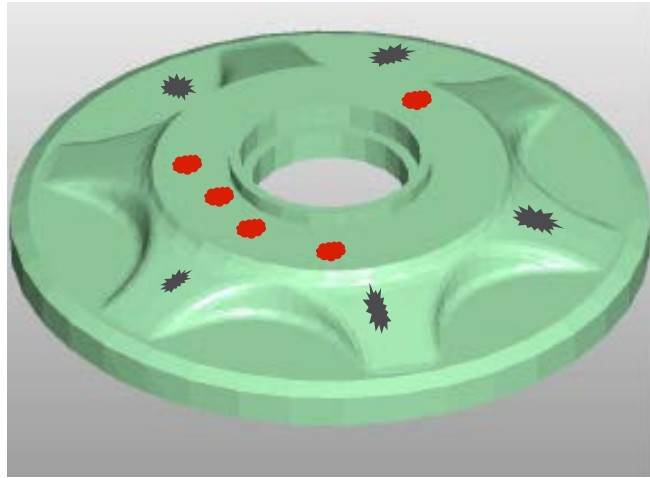

# Growth potential and what are we going to do differently

- Geography
  - China: global support, considerable growth through market creation
  - India: aggressive share gain, market creation
  - Western world: hold position share gain and market creation, reduce costs
- Products
  - Vigorous new product R&D and investment
  - Filtration: differentiation and share gain
  - Feeding Systems: market creation and share gain
  - Binders and Coatings: share gain



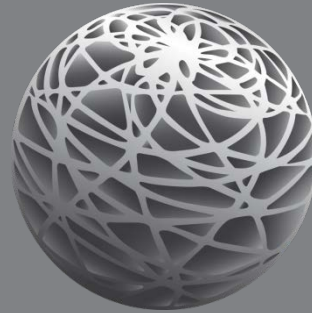

A GLOBAL LEADER IN METAL FLOW ENGINEERING

China

Roel van der Sluis  
President, Vesuvius North Asia

VESUVIUS PLC

# China

---

- Market development steel and foundry
- Vesuvius in China
- Market penetration and potential



# Chinese crude steel output and growth rate 2001 – 2014

Unit: 000,000 Tonnes

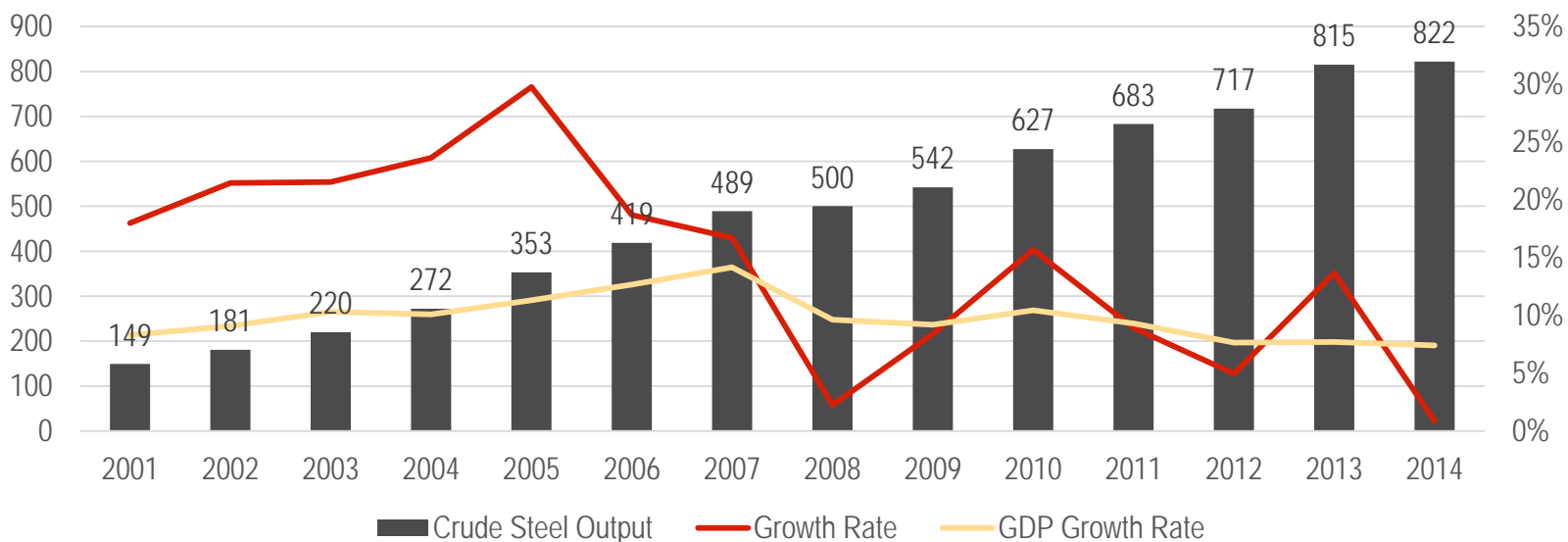

## 2014 Crude Steel Output

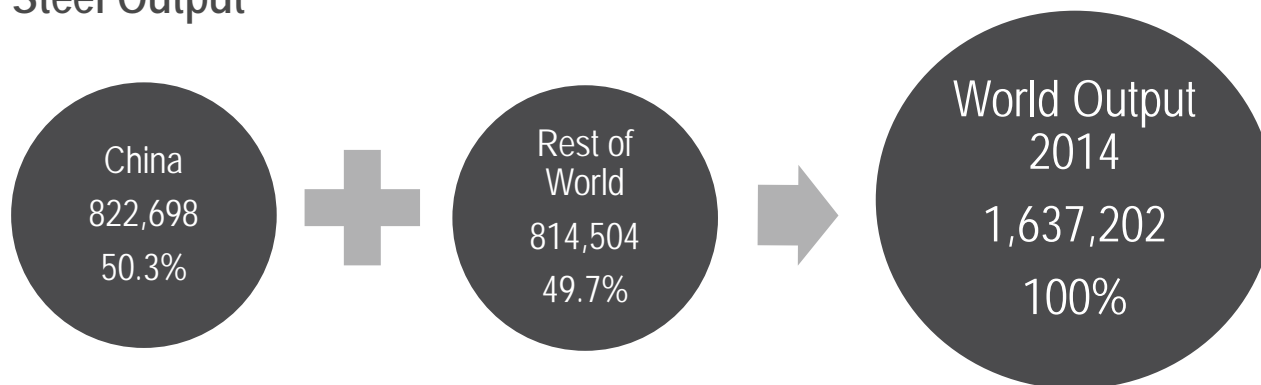

Source: China Iron and Steel Association (CISA) and WSA

# Apparent consumption of crude steel 2009 – 2015

Apparent Consumption of Crude Steel  
2009 – 2015 (Million Tonnes)

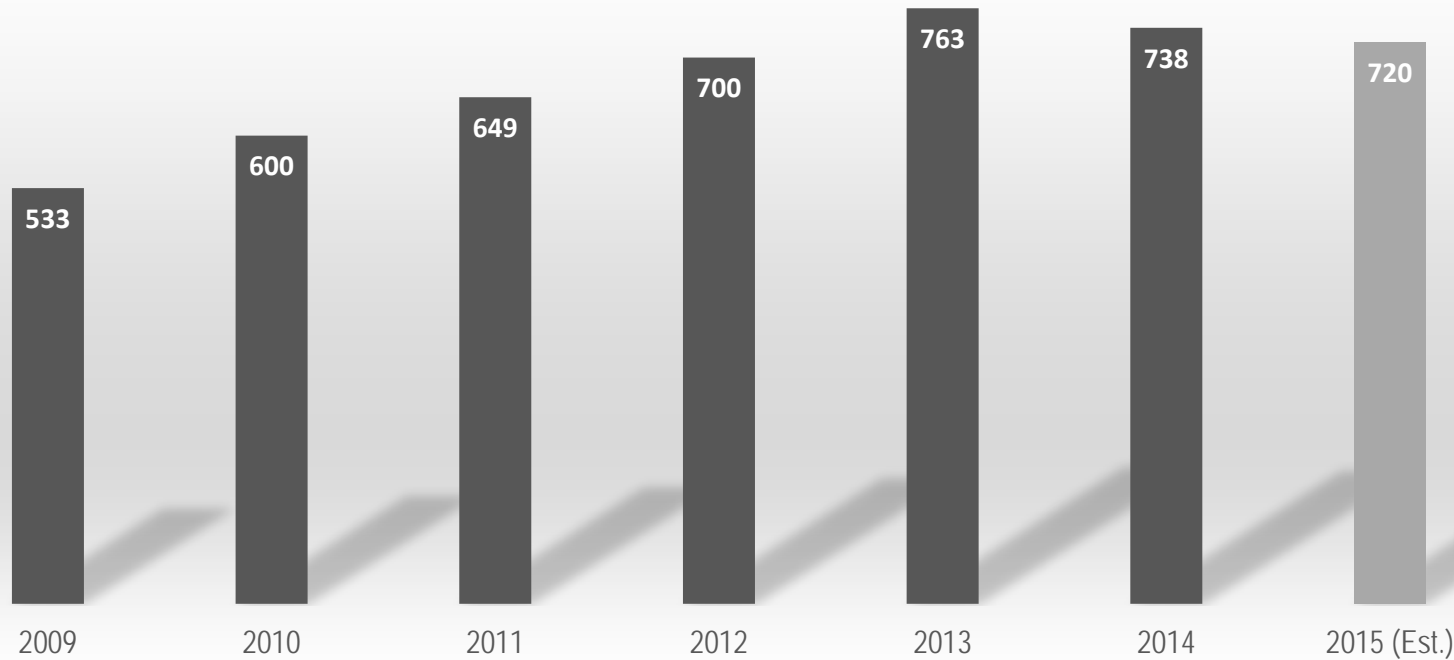

# China casting output and growth rate 2000 – 2014

Unit: 000,000 Tonnes

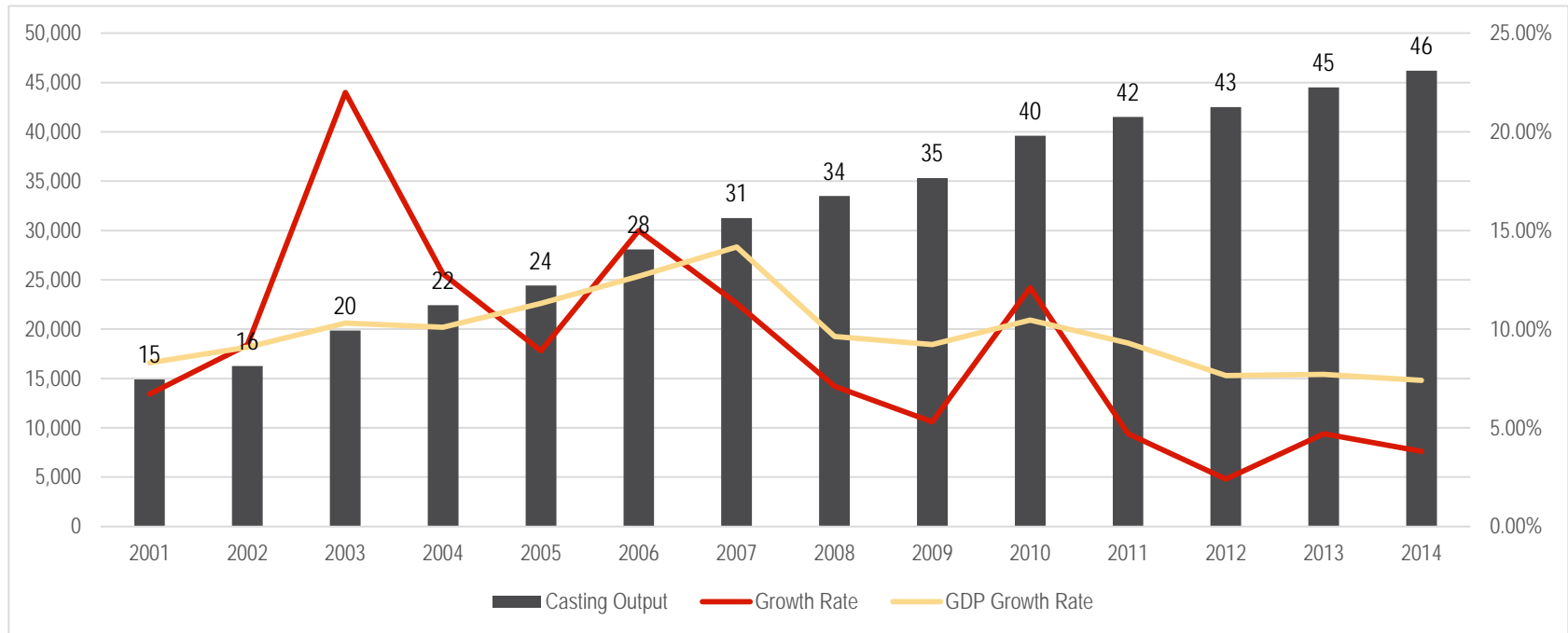

## Casting Output 2014

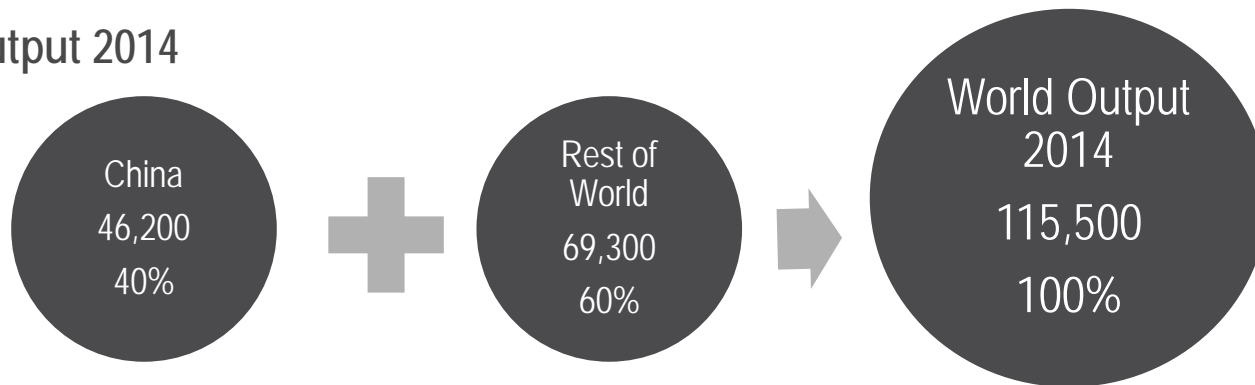

Source: CFA

# Measures to combat overcapacity

- The expansion of steel production capacities went out of control during the past decade
- More than 700 million tonnes of steel capacities built after 2005, only less than 100 million tonnes of which were approved by the government
- The Ministry of Information and Industry Technology (MIIT) re-examined steel production capacities during 2012 – 2014
- 305 steelmakers and 1122 foundries are identified as qualified under the rules and standards set by MIIT for the steel and foundry industries
- Reduce foundry number from 30,000 to 10,000 in 2020
- Output double from 1,320 tonnes to 2,500 tonnes for each foundry





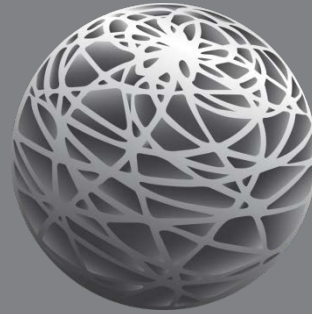

A GLOBAL LEADER IN METAL FLOW ENGINEERING

Vesuvius in China

VESUVIUS PLC

# China Manufacturing Footprint

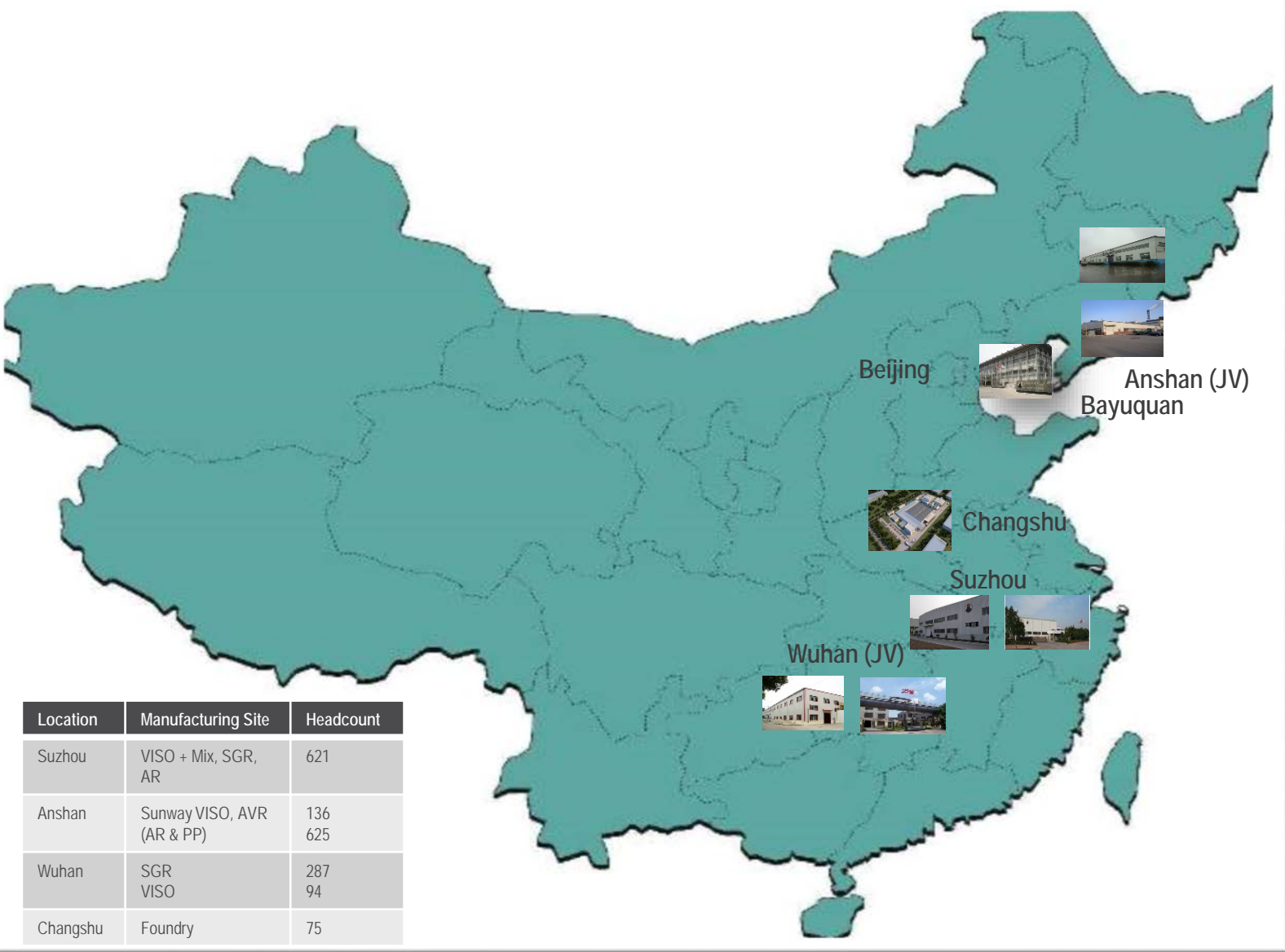

Location	Manufacturing Site	Headcount
Suzhou	VISO + Mix, SGR, AR	621
Anshan	Sunway VISO, AVR (AR & PP)	136 625
Wuhan	SGR VISO	287 94
Changshu	Foundry	75



# Full product offering to drive penetration in China

## Steel Division

- Slide Gate Raw & Assembled Plate
- Slide gate mechanism
- VISO Mix and VISO
- Bricks – MgO – C, Alumina – C
- Precast
- Monolithic

## Foundry Division

- Filter – SEDEX
- FMT
- Crucible
- Fused Silica Roller
- FD Feeding – Sleeve
- Coating ( Solvent and water based)
- Resin binder



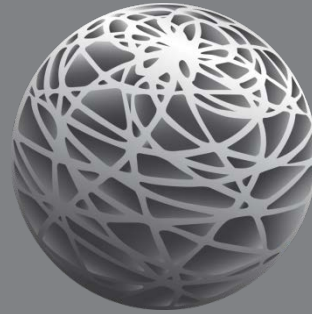

A GLOBAL LEADER IN METAL FLOW ENGINEERING

Our growth plan in China

VESUVIUS PLC

# Q1 output of steel and ratio development between flat and long steel

Type of products	Jan – Mar 2015	Jan – Mar 2014	Growth rate %	2014	2013	Growth Rate %
Total finished steels	195,000	190,125	2.5	1036	1035	0.1%
Flat products	89,661	84,437	6.2	477	450	6.0%
Long products	102,617	103,325	0.70%	559	585	-4.4%
Long / Flat	53/47%	55/45%		54/46%	57/43%	

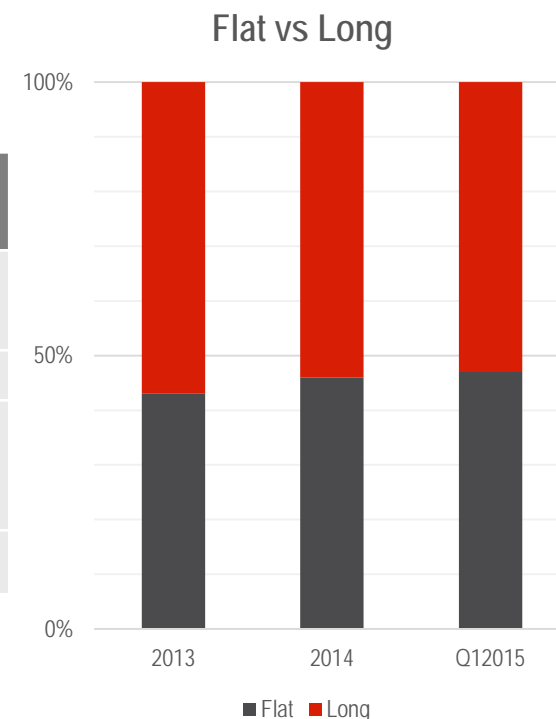

# China casting output by metal type

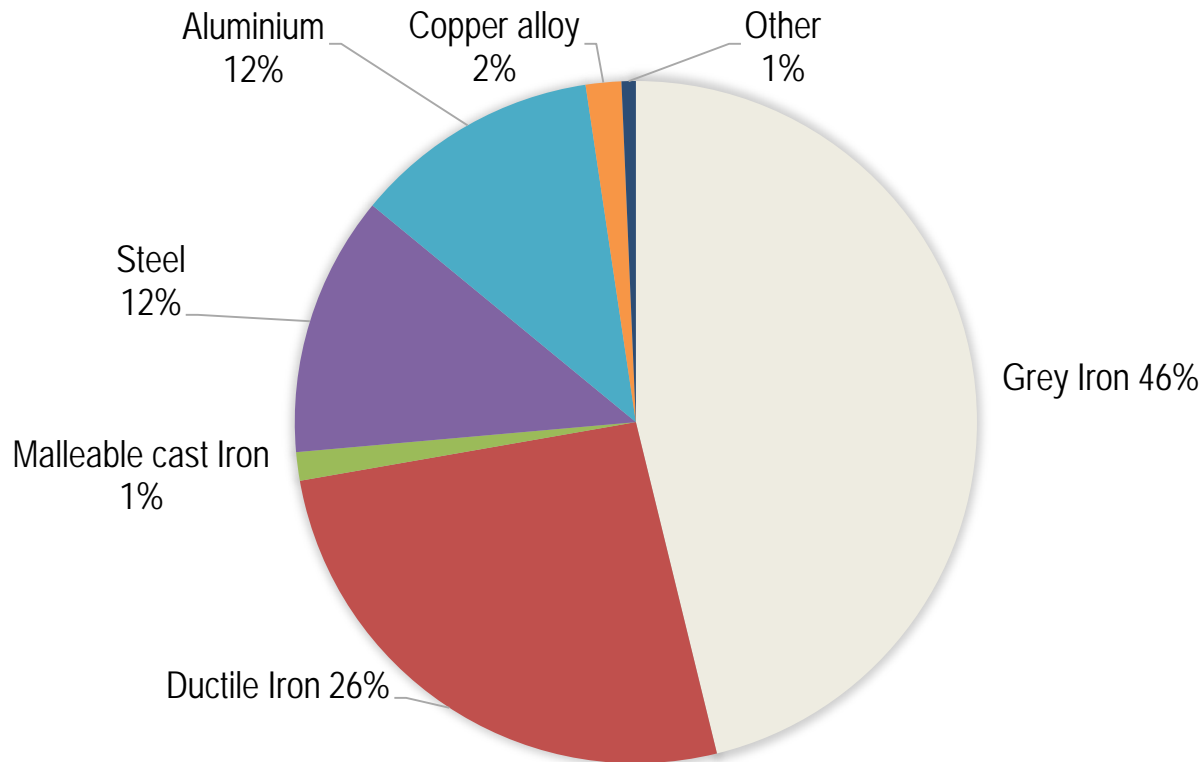

# China casting output by metal type

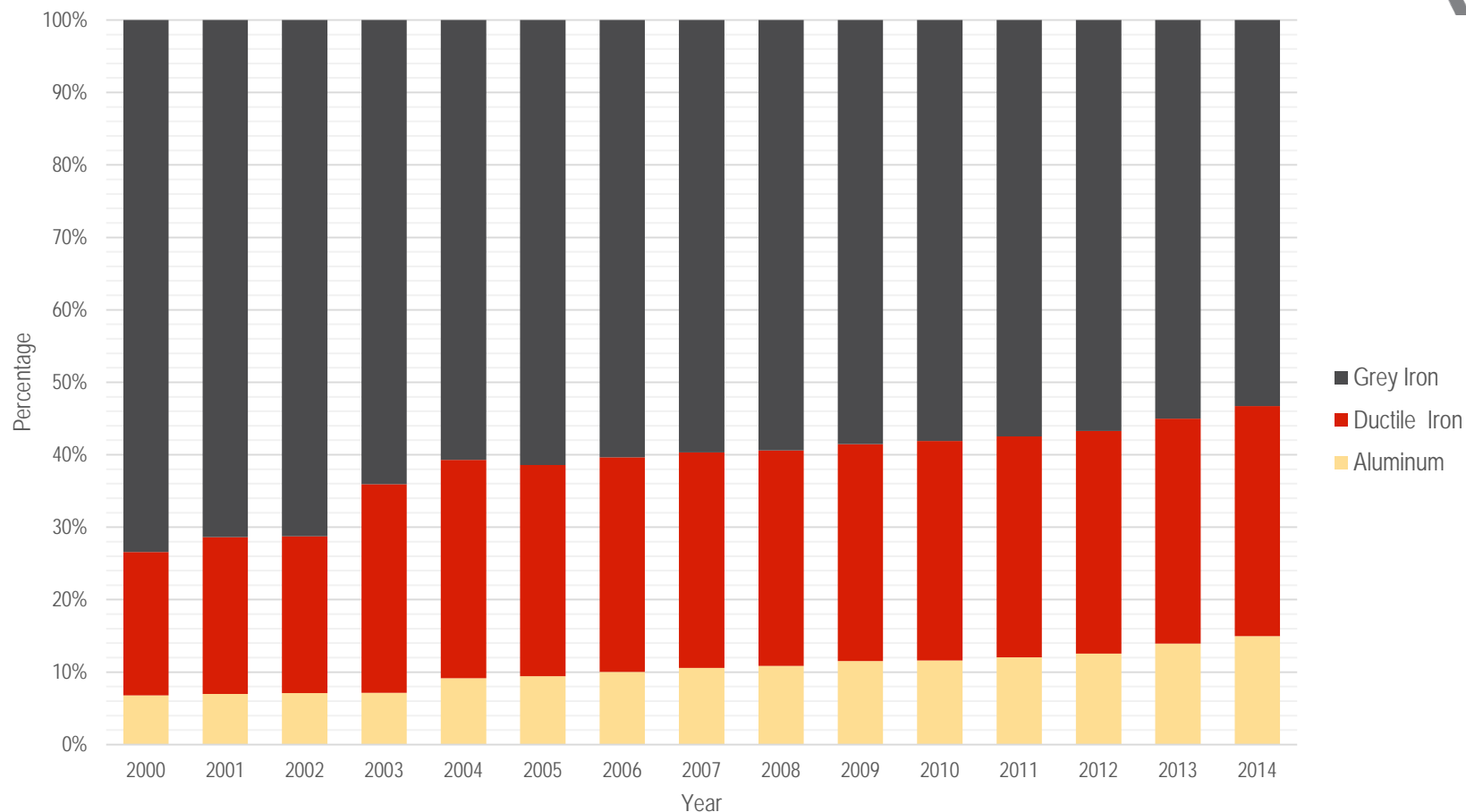

Source:

- Historically output (2000 – 2014) shows a trend of an increase in ductile iron and aluminium and a proportion of ductile iron castings should exceed 30% and non-ferrous castings should be around 20% in future

# Quality is the first requirement

---

- At the center of our action plan to grow the business
- An essential part of our brand equity
- Will support our price premium
- Allows us to resist competition successfully under pricing and grow our market share
- Recent progress in quality has restored our value perceived by customers





# Sales penetration offers a huge potential

## Steel

China

- Output – 822M Tonnes
- Sales penetration – £0.084/T

NAFTA

- Output – 120M Tonnes
- Sales penetration – £2.75/T

EMEA

- Output – 248M Tonnes
- Sales penetration – £1.71/T

## Foundry

China

- Output – 47.2 M Tonnes
- Sales penetration – £0.72/T

NAFTA

- Output – 14.6M Tonnes
- Sales penetration – £5.71/T

EMEA

- Output – 21.7M Tonnes
- Sales penetration – £8.48/T



# Sales penetration offers a huge potential

In 2014

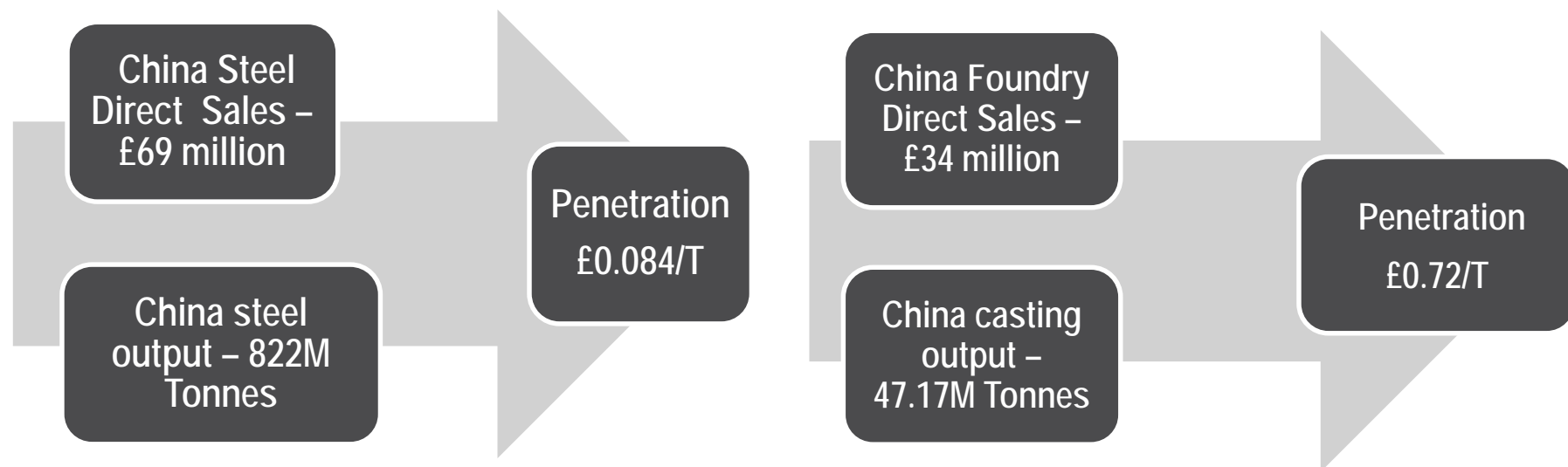

Region	Penetration (£/MT)
NAFTA	2.45
EMEA	1.70

Region	Penetration (£/MT)
NAFTA	5.71
EMEA	8.48

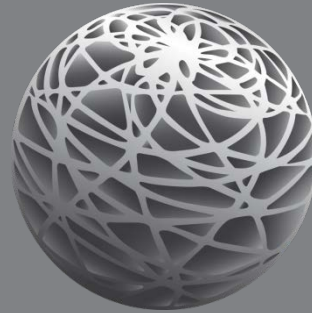

A GLOBAL LEADER IN METAL FLOW ENGINEERING

## Research & Development

Alan Charnock

President, R&D and Chief Technology  
Officer

VESUVIUS PLC

# Research & Development

- Major changes in our customers' processes have been the main driver for the development of our products
- Leading provider of "Solutions through Technology" for the markets we serve
- Robust R&D processes in place to ensure that we maintain this leadership position
- Focused Research and Development targeting new product development
- Lead the innovation drive to establish the Technical Services portfolio



# Vesuvius – Born as a refractory company

## What is a refractory?

- ASTM C71 defines *refractories* as "non-metallic materials having those chemical and physical properties that make them applicable for structures, or as components of systems, that are exposed to environments above 538 °C "



- Refractories are heat-resistant materials that constitute the linings for high-temperature furnaces and reactors and other processing units. In addition to being resistant to thermal stress and other physical phenomena induced by heat, refractories must also withstand physical wear and corrosion by chemical agents.



# Why do we produce refractory?

Our products are used in contact with liquid metal/slag and melted or softening glass

## Application

Steel	1430 – 1540°C
Cast Iron	1150 – 1400°C
Aluminium	660°C
Copper	1084°C
Silicon	1411°C
Glass	1100 – 1500°C

## Refractory Material

Alumina	2050°C
Magnesia	2840°C
Fused Silica	1725°C
Zirconia	2680°C
Graphite	3600°C

## Melting Temperature

1430 – 1540°C
1150 – 1400°C
660°C
1084°C
1411°C
1100 – 1500°C

## Melting Points

2050°C
2840°C
1725°C
2680°C
3600°C

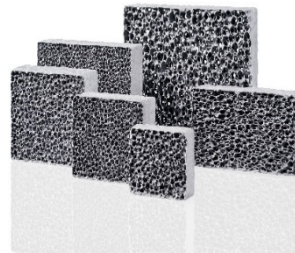

# Development drive from the market



# Development drive from the market – Casting technology roadmap

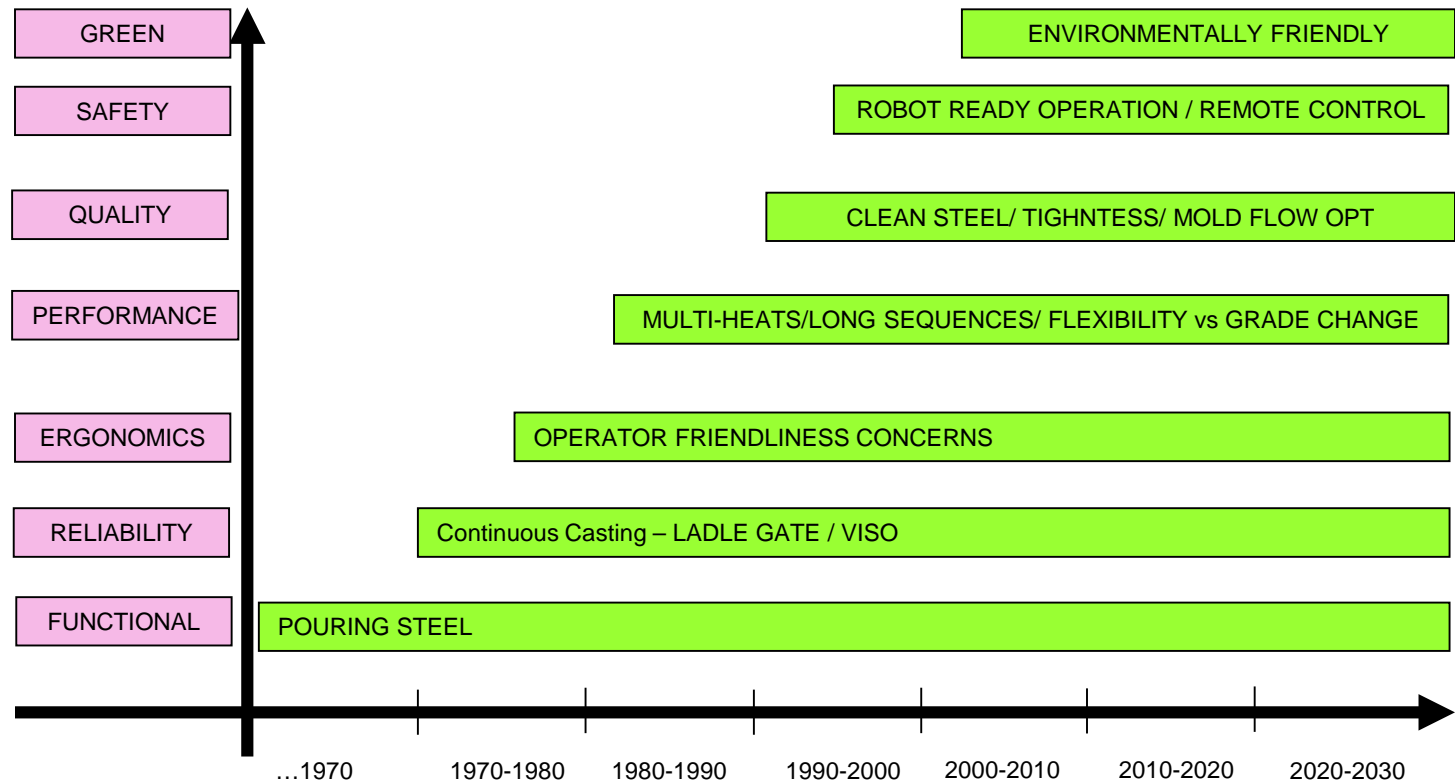



# Vesuvius – Evolving to be a metal flow engineering company

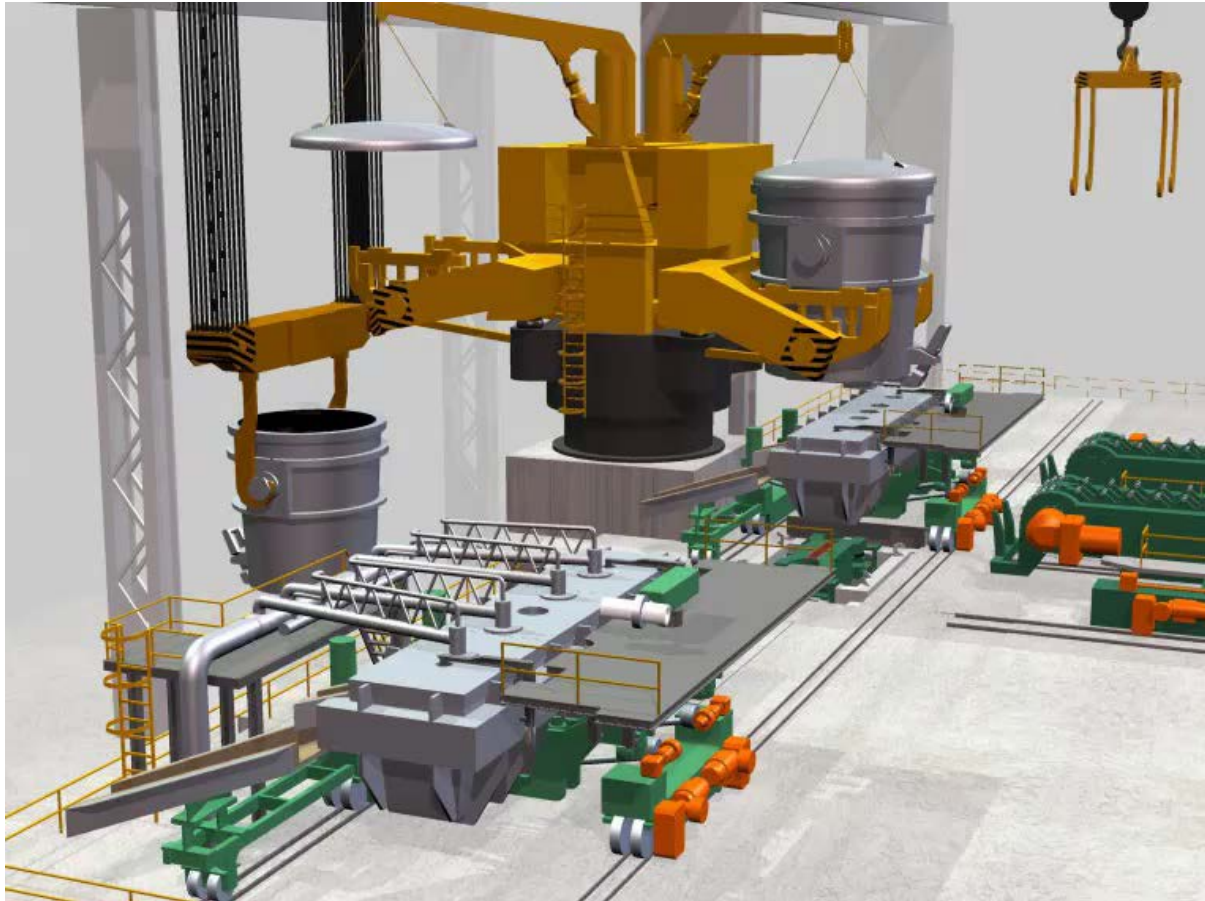

# Vesuvius – Evolving to be a metal flow engineering company

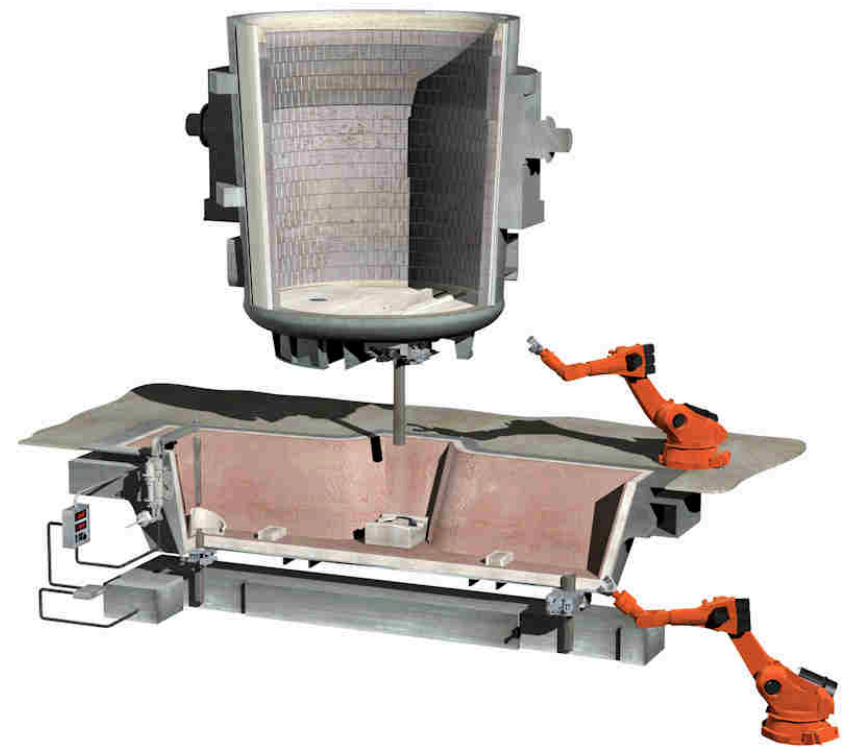
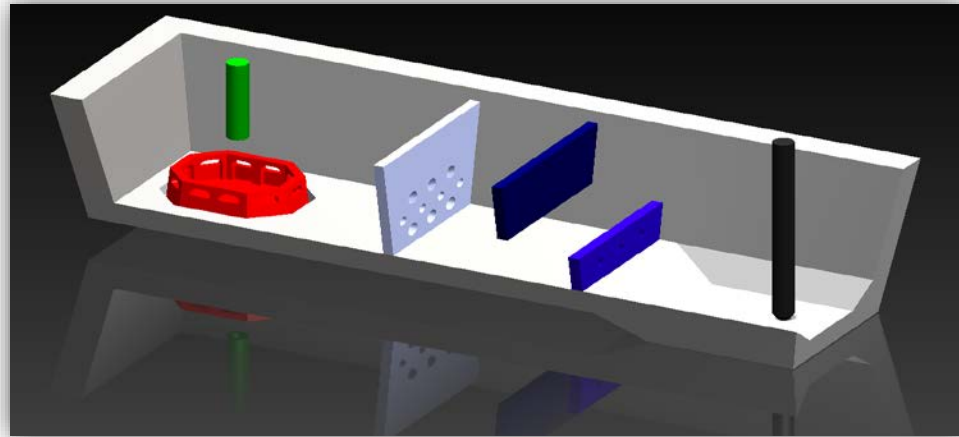

# What our products help to make

## Ferrous and Nonferrous castings

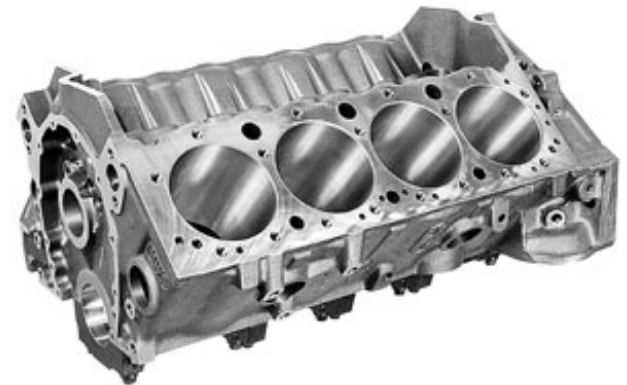

# What our products help to make



Pipes, sheet, sections – to create cans, cars, trains, buildings and bridges



# Our mission and objectives

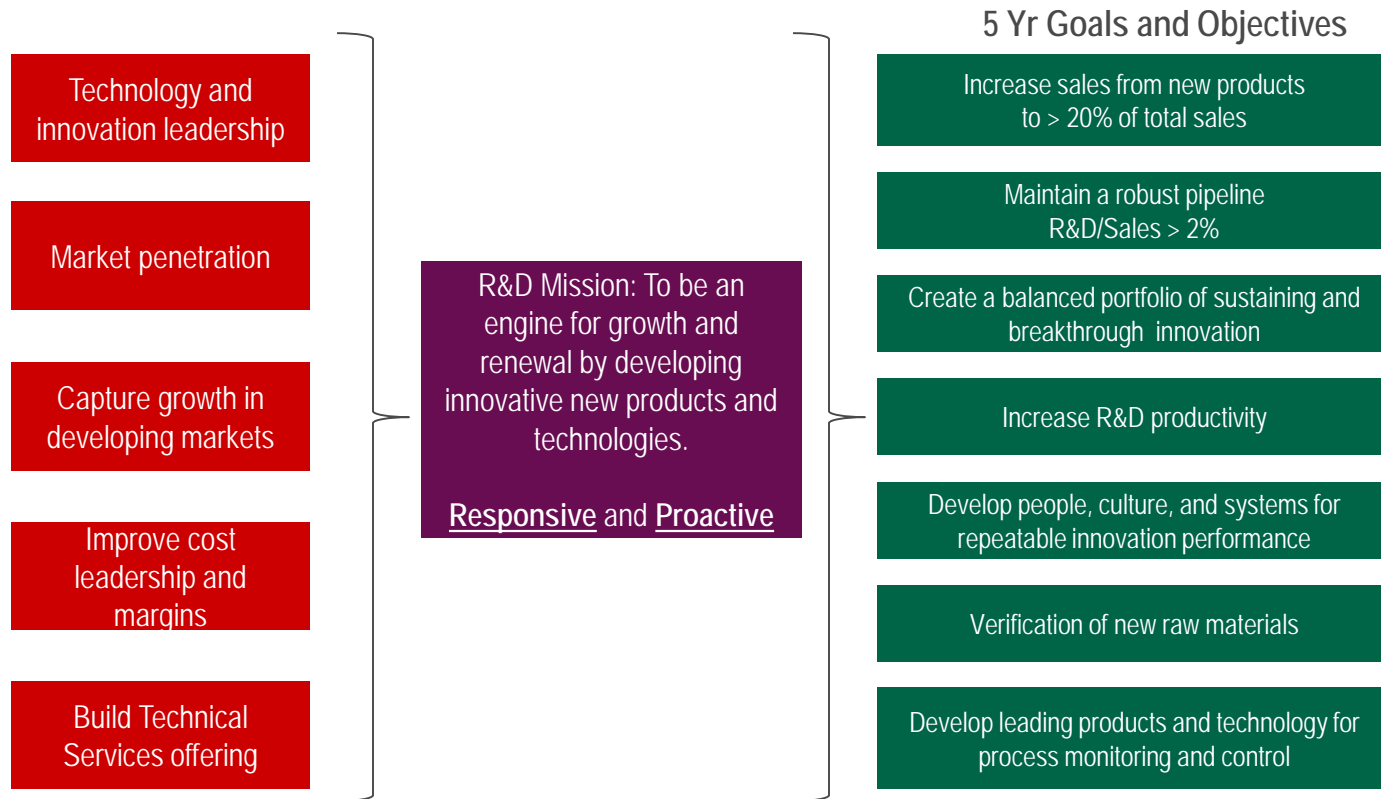

# Robust business processes for innovation

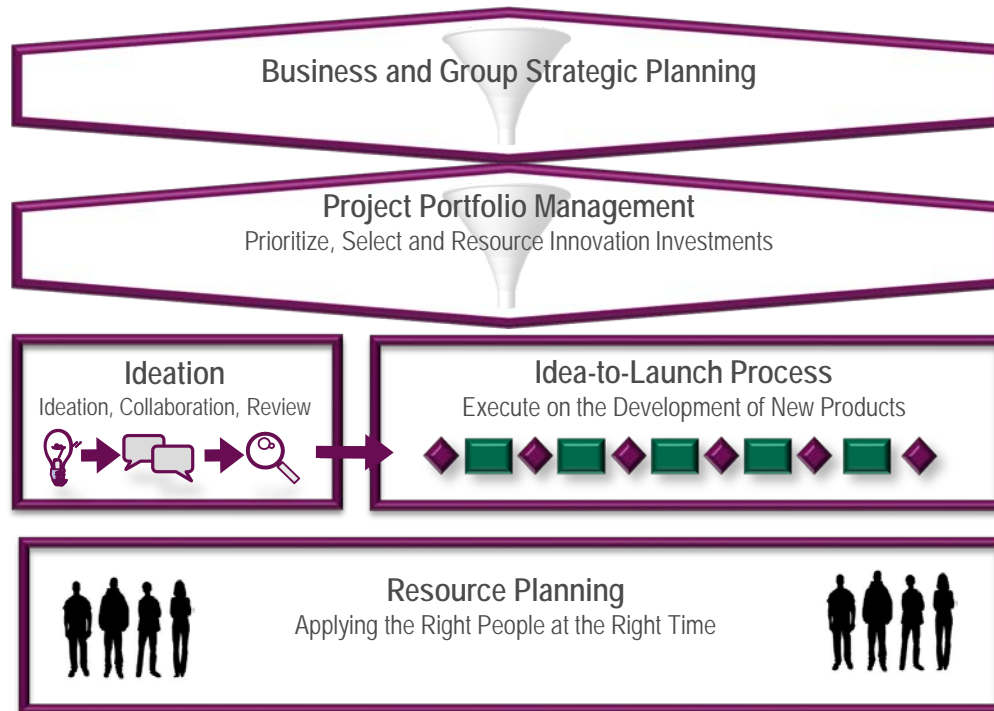

The Prize: 25% – 50% Improvement in “Time to Market” and “Likelihood of Success”

# R&D KPI's

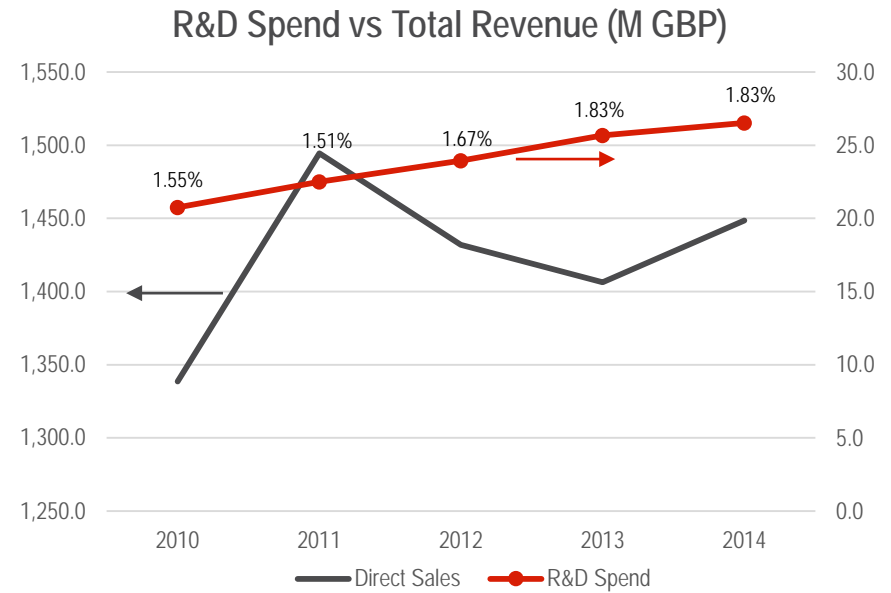
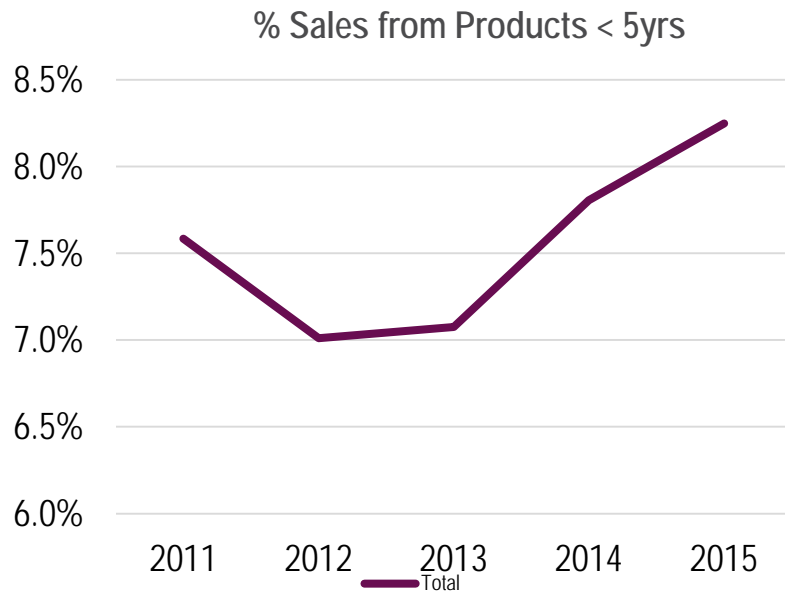

Our Patent Portfolio consists of 1805 active patents granted in 162 Families

# Global R&D and local development labs

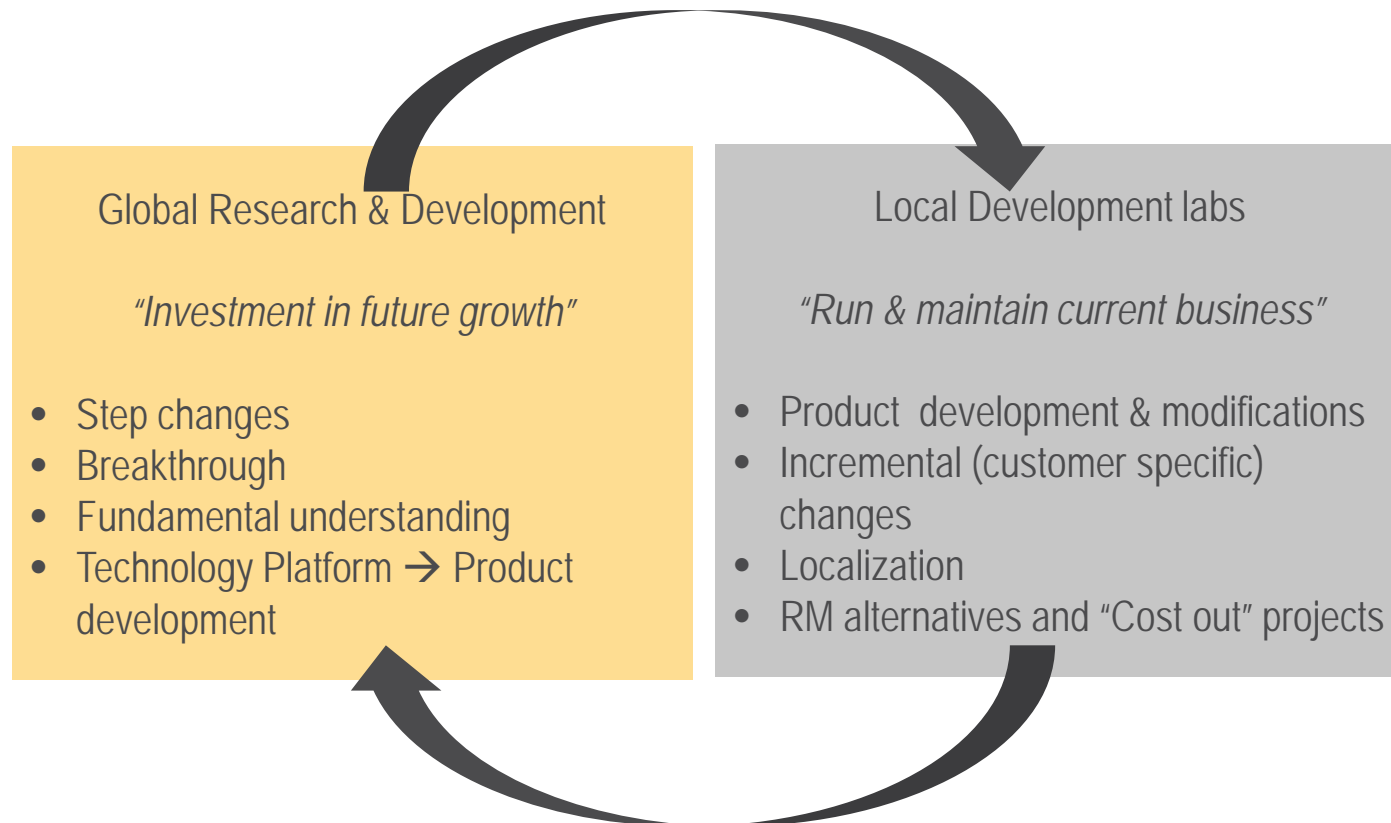



# Vesuvius R&D and Simulation Centers

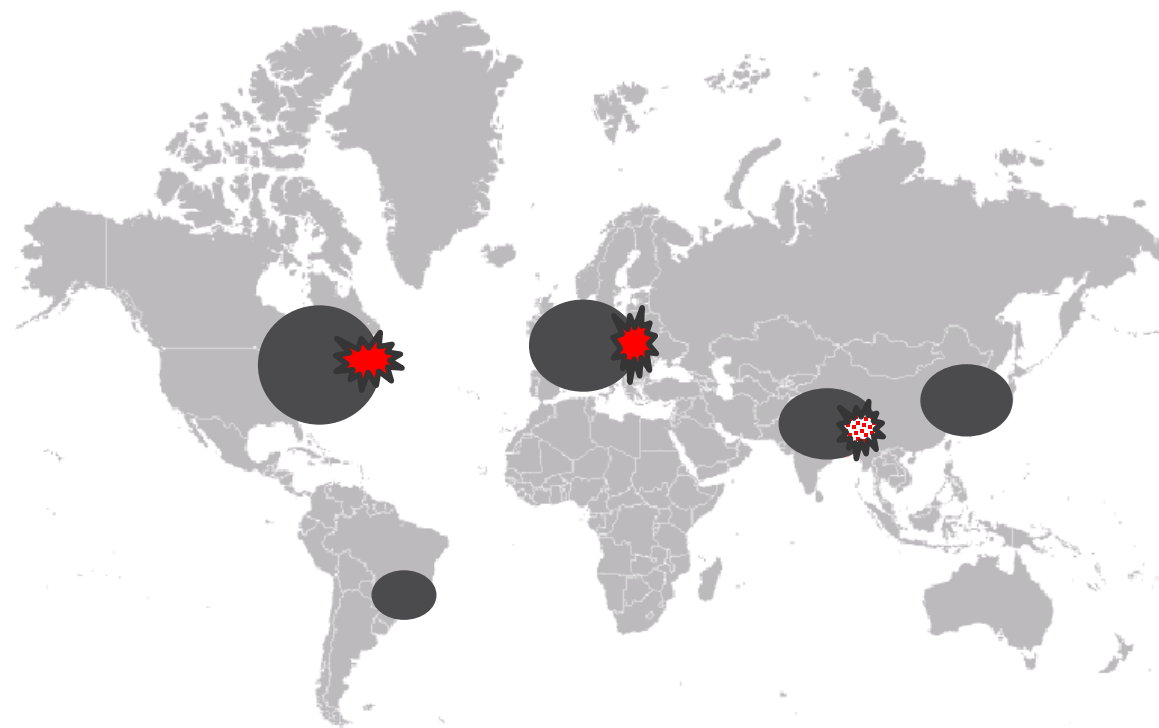

<b>Europe</b>	COE:	BB / EN / FE / GH
	Dev Center:	BK / TM / SR / LY / ST / HO
	Sim Site:	BK
<b>NAFTA</b>	COE:	PI / BV
	Dev Center:	CP / CD / PL
	Sim Site:	PW / CD
<b>South America</b>	Dev Center:	SP / PD
	Sim Site:	RJ
<b>India</b>	Dev Center:	PU / VS
	Sim Site:	CL
<b>N. Asia</b>	Dev Center:	SZ / TP
	Sim Site:	SZ
<p>&gt;300 R&amp;D staff Acronyms of locations for where centers and sites located</p>		



# Method simulations: Magma

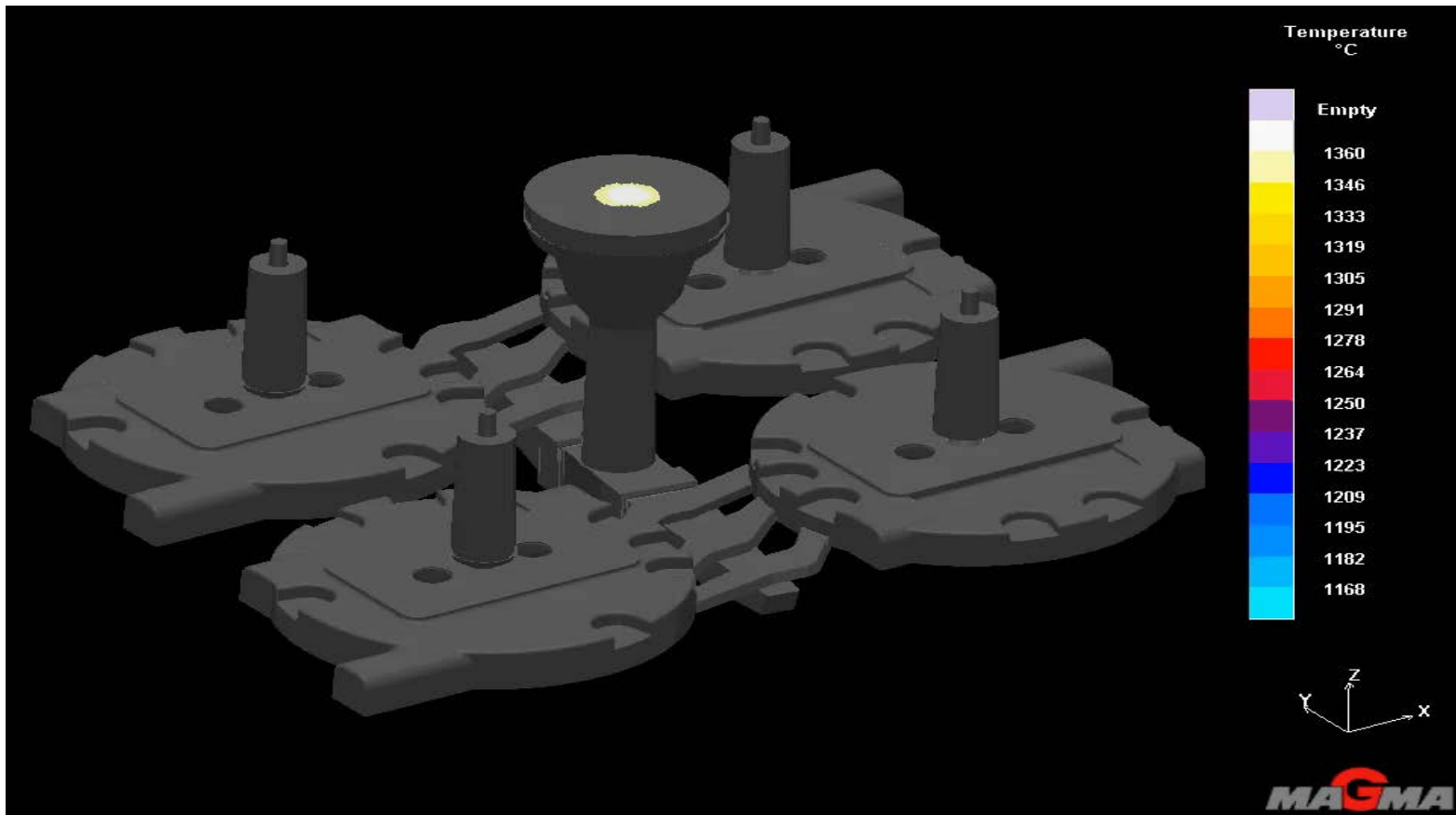

# Method simulations: CFD and Physical Modelling



Air in Steel 0.06 liter

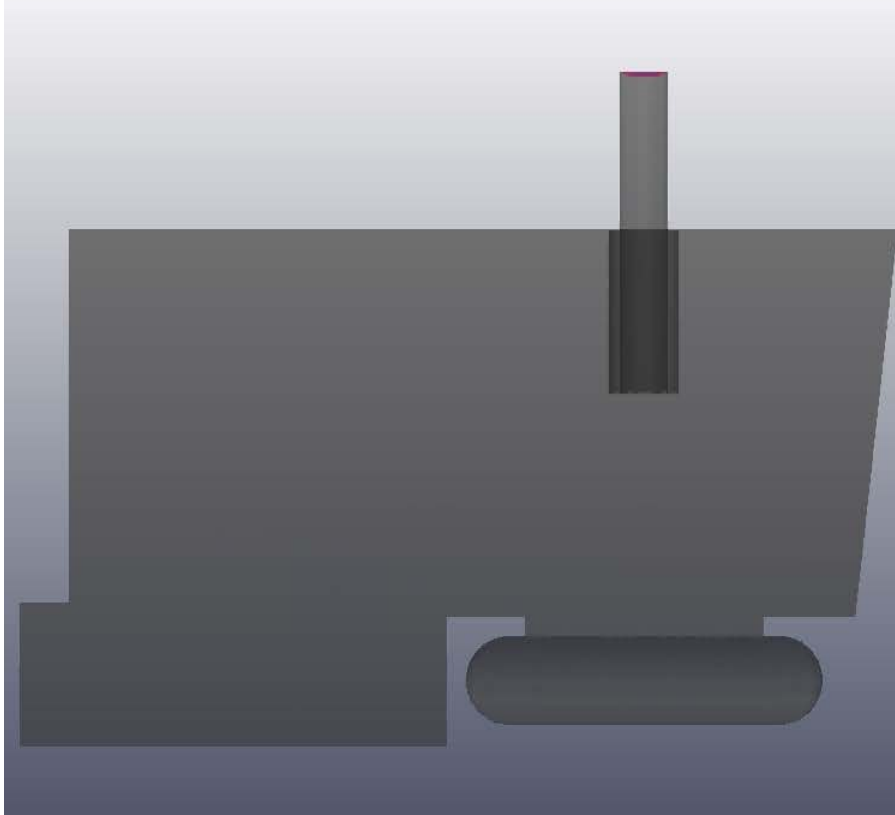

Air in Steel 0.05 liter

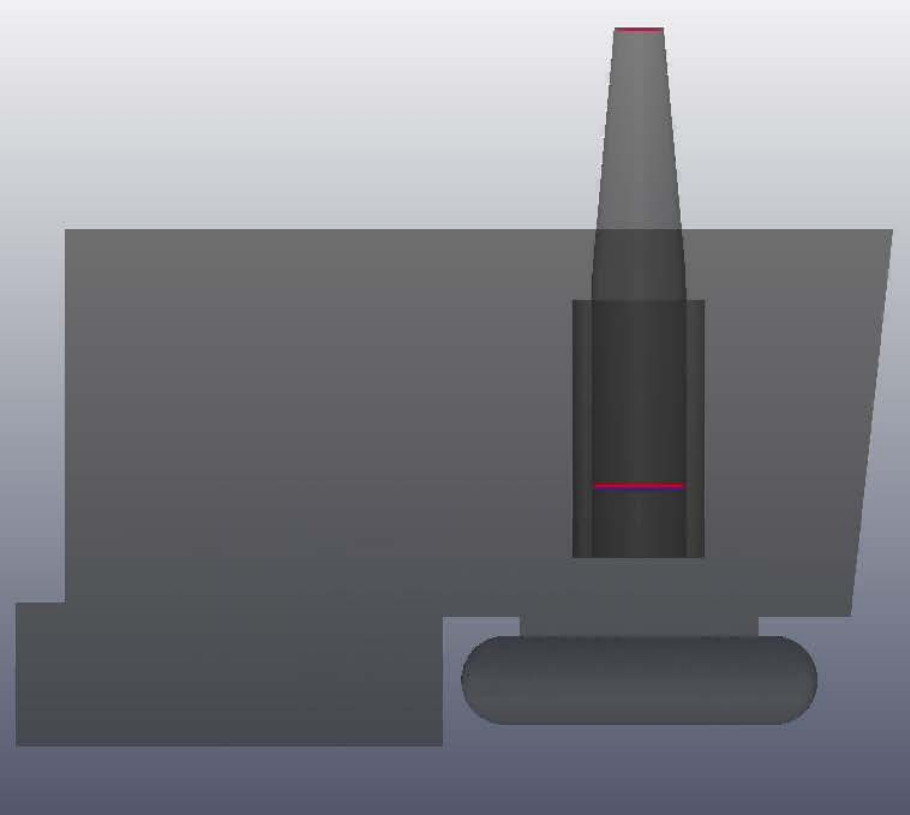

# Enabling Technologies – support to innovation



Cold start technology

- ~ 10% of the R&D spend
- US & EU based
- University and other external Partnerships
- Emerging Technologies / Technology Watch
  - Clogging phenomena
  - Carbon pickup
  - Filtration efficiency
  - Composite materials
  - Nano technology
  - 3D Printing

Inert tundish barrier



Side dams for twin roll strip caster

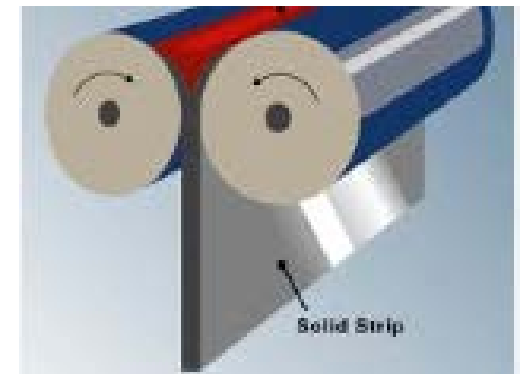

# And now a Technical Services company – real time data capture

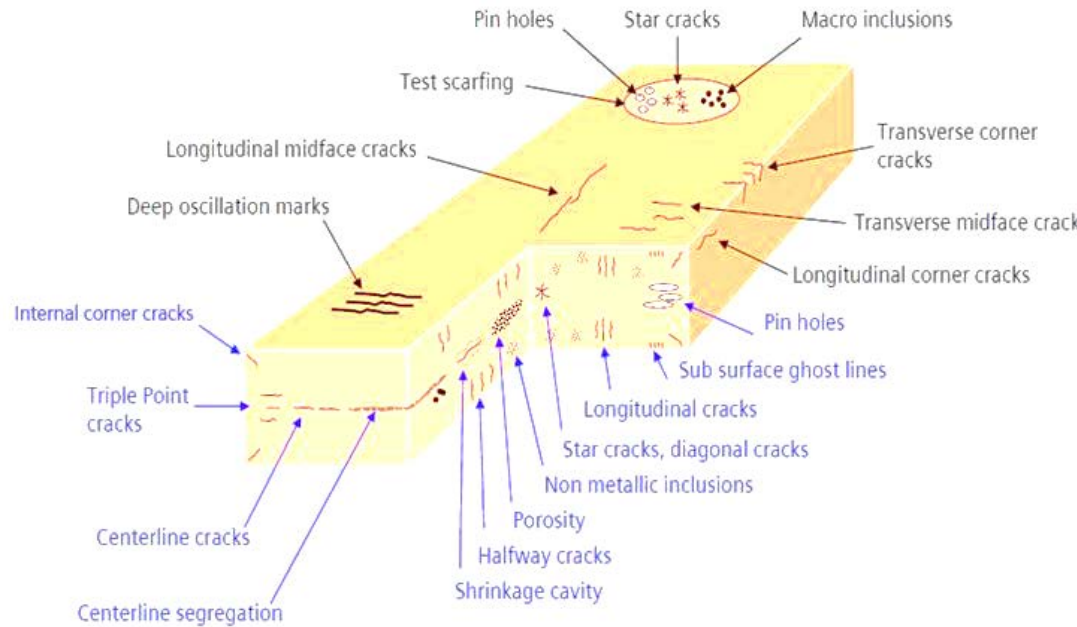
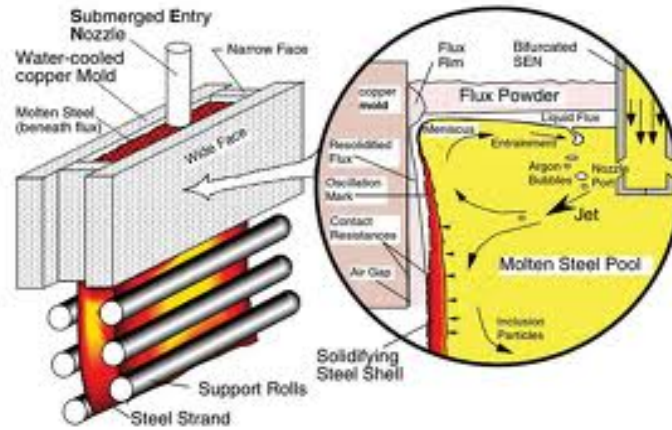

# R&D Conclusions

---

- Targeted ideation
- Robust new product pipeline
- Strategic acquisitions
- Complete symphony of products and technology
- Solutions through technology
- Monitor R&D KPI's



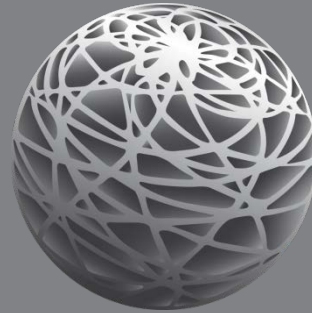

A GLOBAL LEADER IN METAL FLOW ENGINEERING

## Technical Services

Luis Reyes

President, Technical Services

VESUVIUS PLC

# Technical Services

- Vesuvius has accumulated substantial know how and built a strong reputation for quality and expertise
- R&D has always been an important part of the DNA of the Company allowing it not only to participate in new markets but in many cases create new ones
- The proximity with its customers has allowed Vesuvius to understand process information in different parts of the production stages. This information can be used to develop process expert technology to allow customers better decision making





# Technical Services: Business description

- Technical Services is a new business segment for the group to complement existing product lines and develop new products and markets
- Focus on data capture of key process parameters complementing this with Vesuvius' strong presence and expertise in metal casting to create new products, technologies and integrate into process expert systems
- Progressively enter a new market segment which is complementary to existing Vesuvius markets in metal casting



# Technical Services: Main business drivers

---

- **Safety:** Operational standards and regulations have become tighter and pose a bigger challenge to metal producers
- **Quality:** Market forces are placing bigger constraints on metal producing processes requiring deeper and tighter process control
- **Cost:** To increase productivity without jeopardizing safety and quality the production process requires more integration upstream and downstream to allow operators to make quicker decisions



# Framework

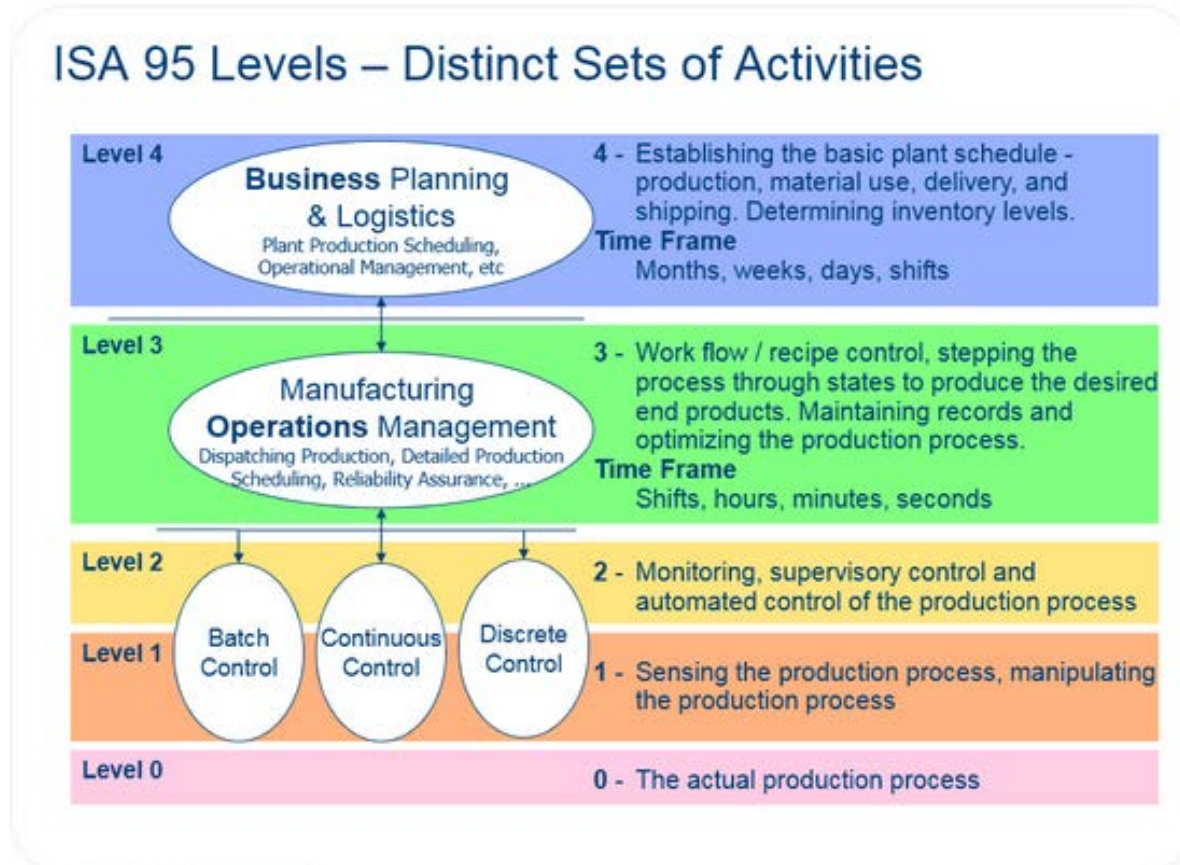

**ANSI/ISA-95**, or **ISA-95** is an international standard from the International Society of Automation for developing an automated interface between enterprise and control systems. This standard has been developed for global manufacturers. It was developed to be applied in all industries, and in all sorts of processes, like batch processes, continuous and repetitive processes.

# Technical Services: Development and growth

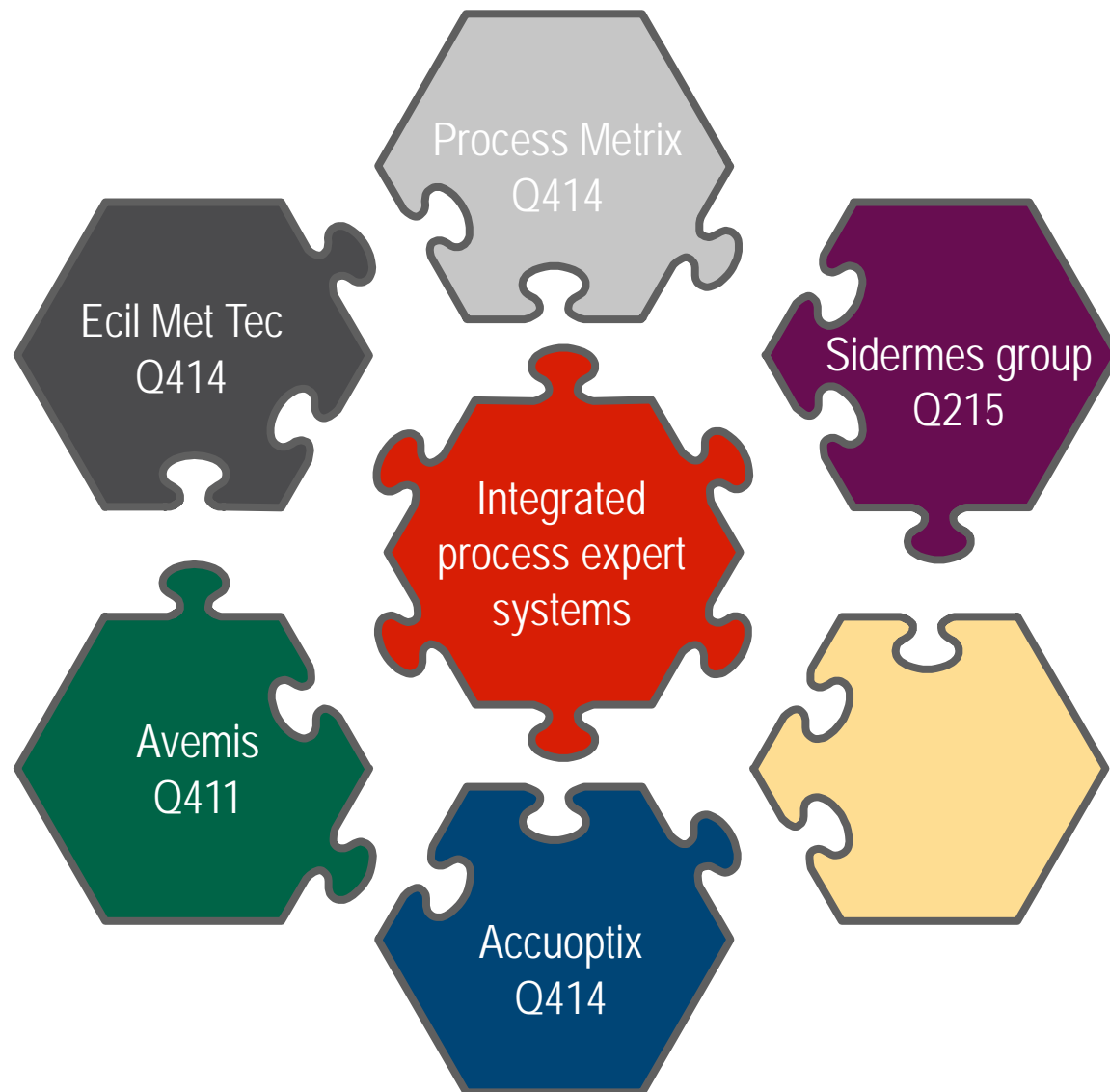

# Technical Services: Existing market segments and portfolio

- The initial applications are segmented in three main areas looking for immediate synergies with other business units:
  - Furnace data acquisition: Chemistry sensors and laser scanner services
  - Ladle data acquisition: Laser scanner services and slag prevention technology
  - Caster data acquisition (Tundish + Mould): Continuous temperature sensors and mould information technologies.





Furnace data acquisition

## Temperature and Chemistry Sensors



# Technical Services: Ecil Met Tec + Sidermes sensor technology

**Thermocouples**



**Oxygen Probes**



**Immersion Samplers**



**Combined Probes**



**Thermal Analysis Sensor**



**Substance Probes**



*Ecil Met Tec + Sidermes - Full Manufacturing, vertically integrated, Facility (all products heads, Hardware, Instruments, Paper Tubes and Tubing & Packaging)*

**Hydrogen Sensors and System**



**Wireless Instruments**



**Hardware**



135

## Typical Disposable probe designs

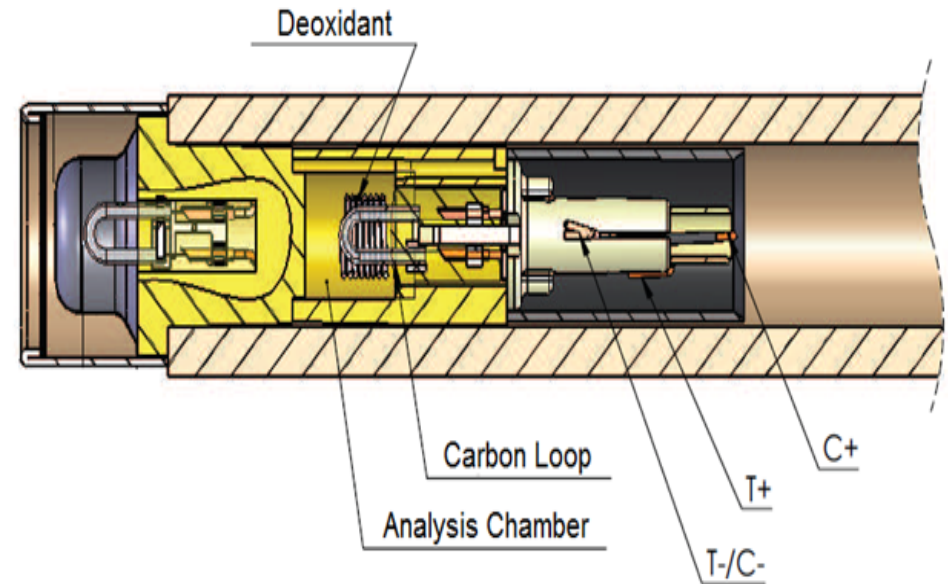
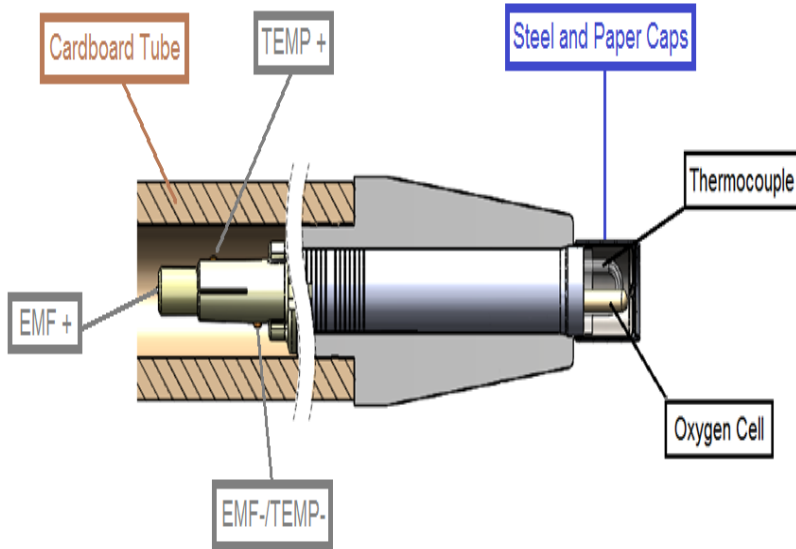



# Technical Services: Process Metrix – vessel laser scanning

- Purpose-built hardware and software for the steel mill environment
- Patented Laser Tracking System Auto-location
- Wireless transmission of vessel tilt
- Single mouse-click measurement control
- Fast data analysis (1 – 3s)
- Fast scan time, complete furnace measurement in 3 minutes
- 100% control of supply, service and support

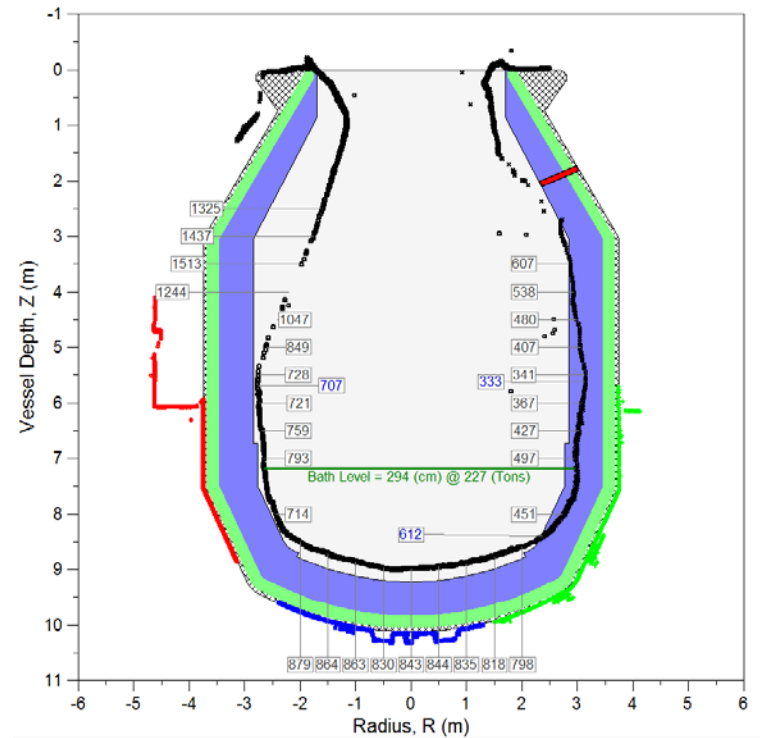



Furnace and ladle data acquisition

## Laser scanner

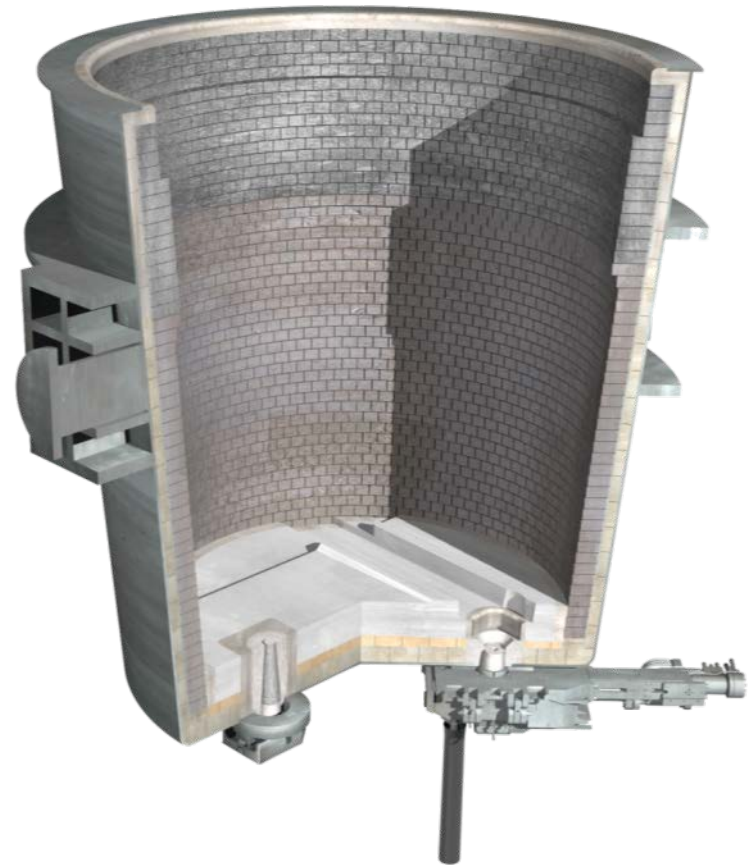

# Technical Services: Process Metrix laser scanning

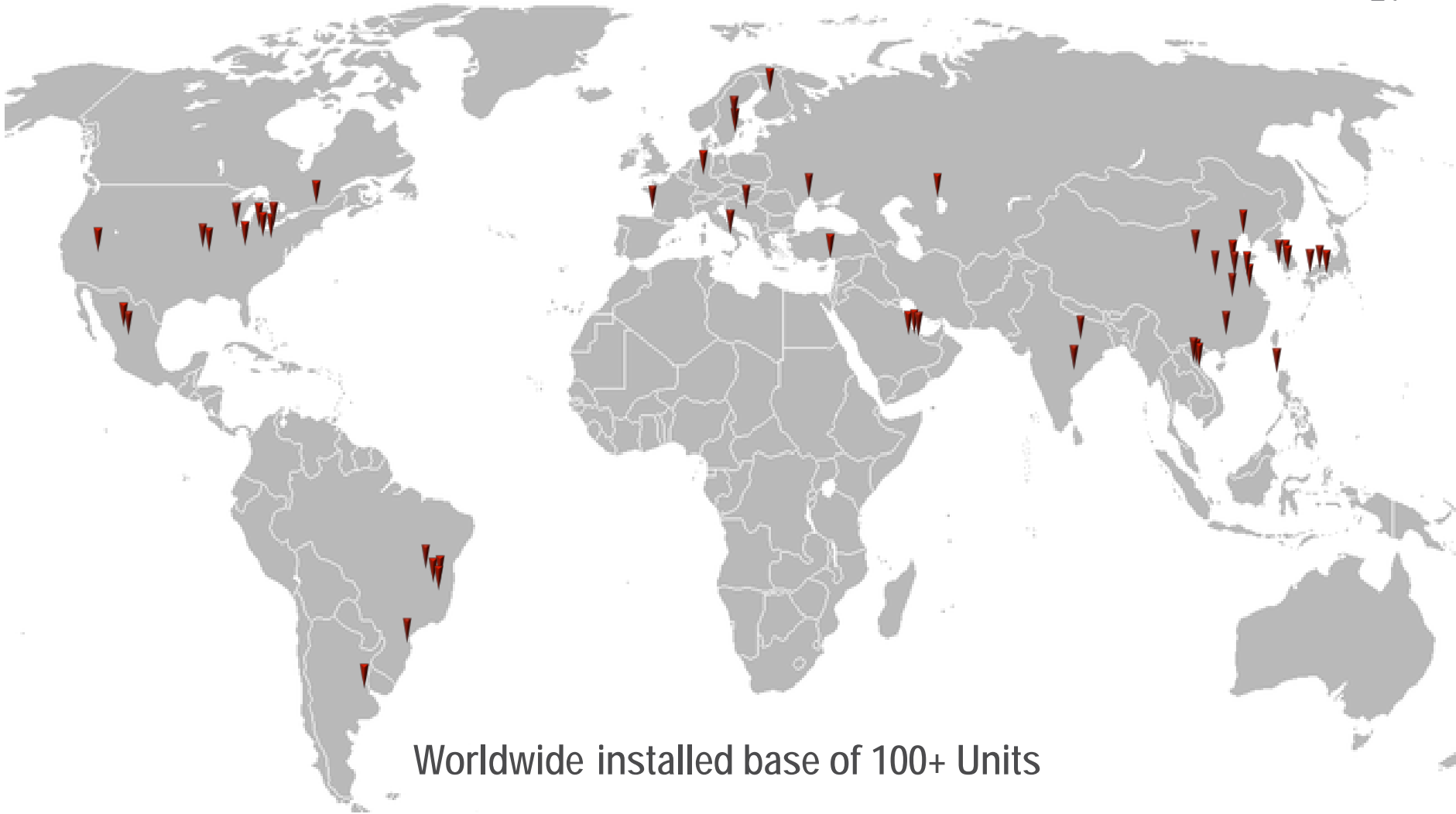

Worldwide installed base of 100+ Units

▼ = ~40% market share – annual sales basis



# Technical Services: Process Metrix laser scanning

- Safety – Targeted analysis of areas of concern
- Cost – Provides detailed analysis of lining residual thickness to allow accurate wear out analysis in order to extend refractory lining life safely
- Cost – Increase shop productivity by better Schedule vessel wear and down time
- Quality – Accurate and repeatable measurement improve material selection



Laser Scanner in standby



Laser Scanner in operation

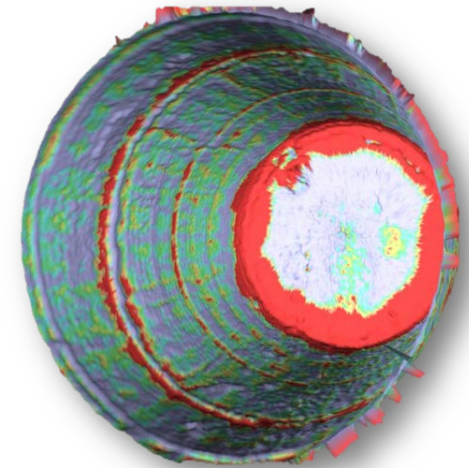

Ladle 3D scan





Tundish data acquisition

## Continuous temperature and slag prevention systems



# Technical Services: Avemis Accuoptix Continuous Temperature Measurement (CTM)

## CMD Advantages

- Safety – Removes need for operator taking temperature samples at casting platform
- Quality – Makes casting near optimum temperature more achievable
- Cost – Reduces energy waste by overheating upstream and reduces downstream process defects associated with over/under heating



## Manual version

Mounting in tundish prep area

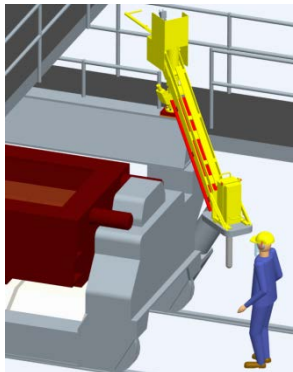

## Manipulator version

Assisted handling of the device at cast platform

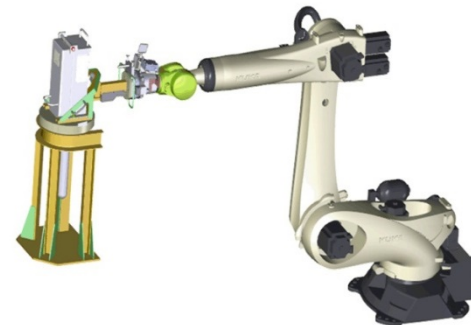

## Robotic version

Fully automated unit set up and removal without operator intervention

## Thermocouple CTM (Accucone / Accumetrix)

- Legacy & Mature Technology in NAFTA
- Expand to other geographies

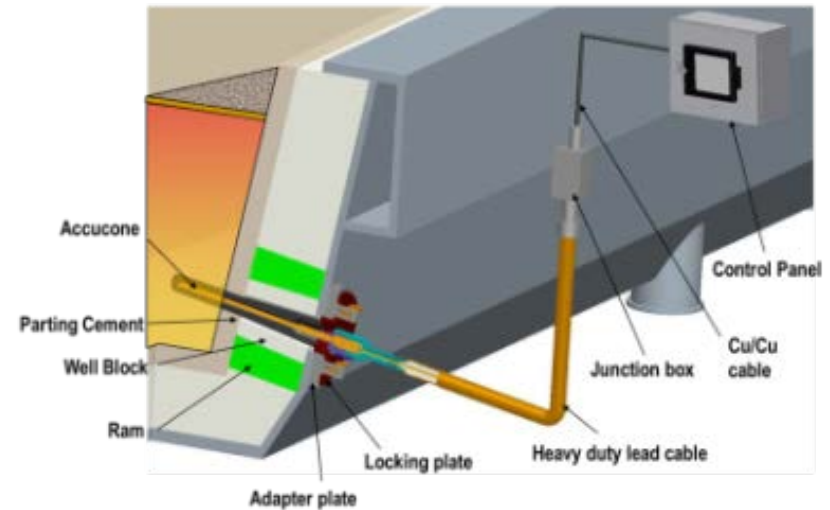

## Optical CTM (Accuoptix) – Beta Phase

- Alpha Trial in 2014, BES converted
- ~ 5 – 10 projects expected for 2015



# Technical Services: Avemis RADAR T2

- Radar is a detector of slag in the ladle taphole to help closing the gate before slag goes to the tundish
- Vibration Slag detection system (continuously online during one month ~ 460 Heats)

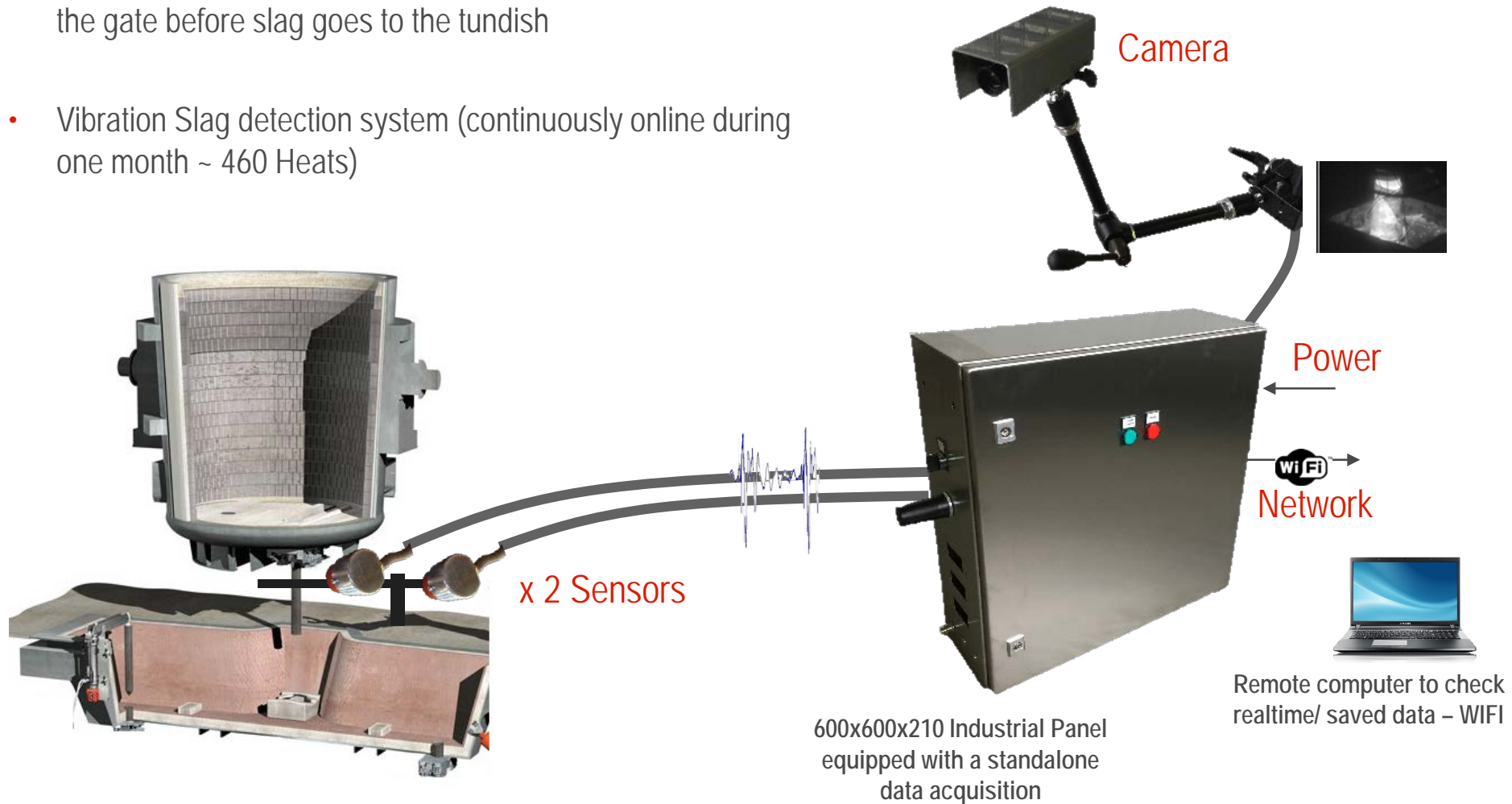





Mould data acquisition

## **Mould level sensor and mould audit unit**



# Technical Services: Avemis mould technology

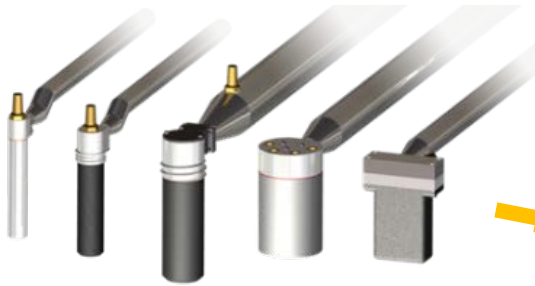

XLEV – S Suspended Mould Level Sensor  
• Launch: 2007

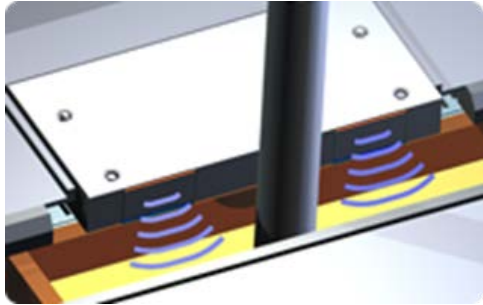

XLEV – L Ledge Mould Level Sensor  
• Launch: 2010

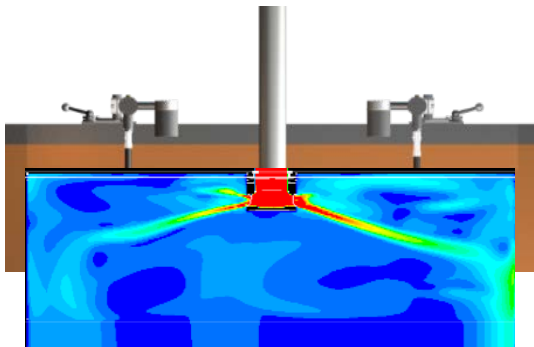

XMAT – Mould Audit Unit  
• New



# Technical Services: Avemis mould audit technology

## Benefits

- Mould «black box» understanding
- SEN/ SES design performance evaluation
- Flow simulation model validation
- Surface quality improvement

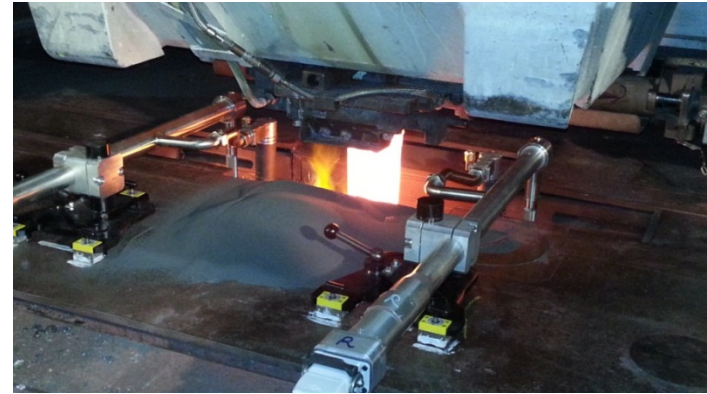

*Alpha Trial at an European customer Dec 2014*

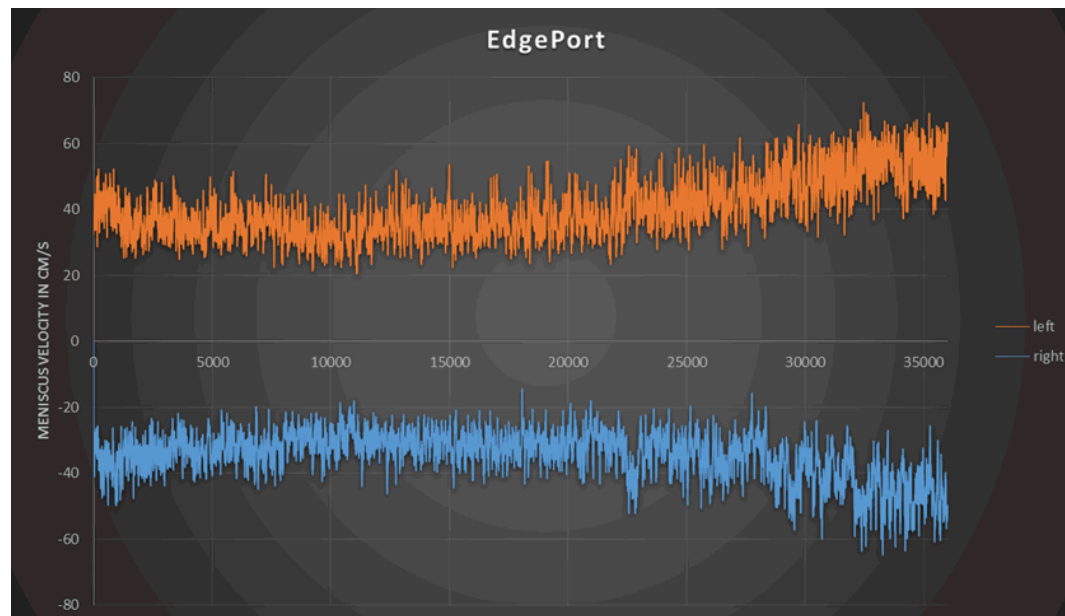

## First Results

Good matching simulation vs actual velocity measurement



# Technical Services: Avemis mould audit technology

X-Mat is a combination of data collections that allows manufacturers to follow the flow of metal in the mould to ensure the best quality of the metal solidification surface

## Benefits

- Mould «black box» understanding
- SEN design performance evaluation (metal delivery)
- Flow simulation model validation
- Surface Quality improvement (laminar flow vs turbulent flow)

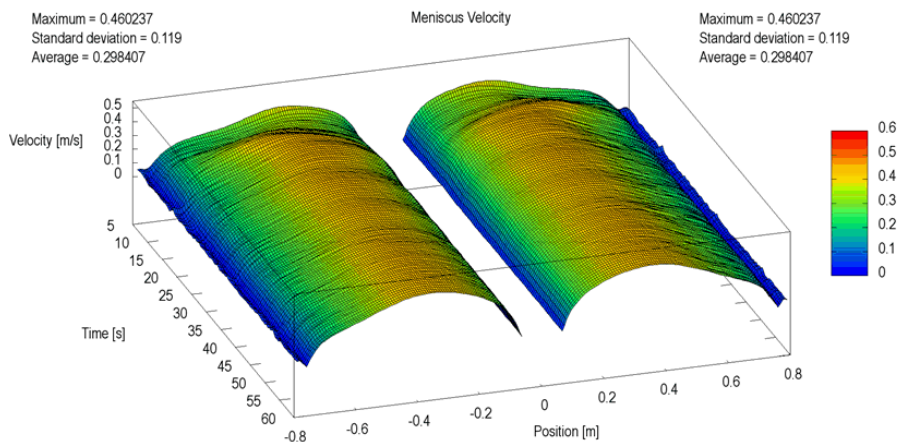

3D Scan of actual cast at alpha site

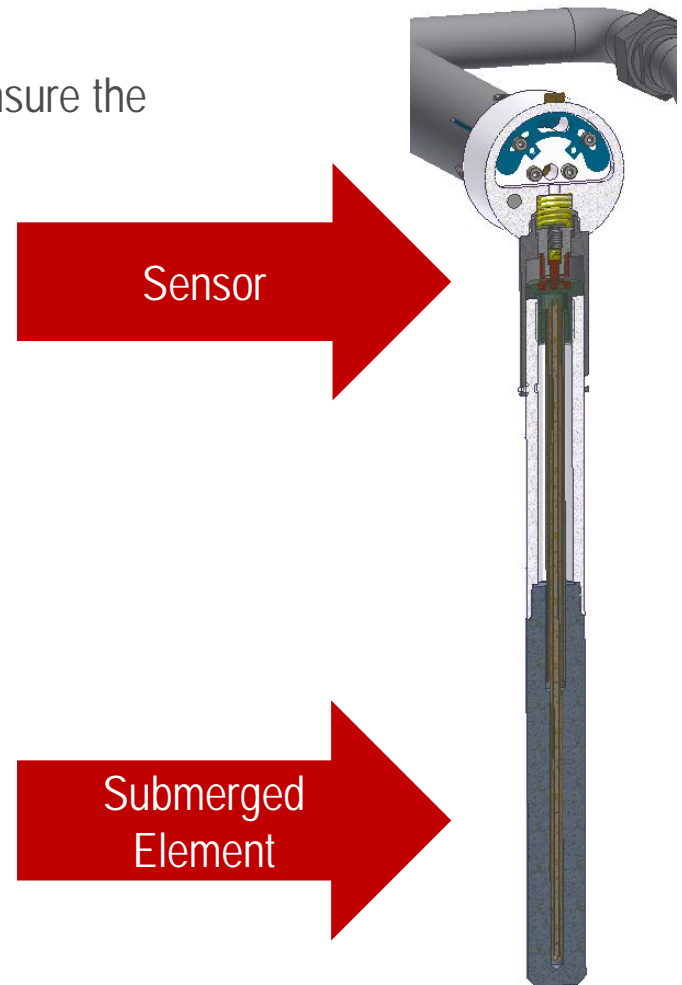

Schematic of sensor design

# Technical Services: Conclusions

- Vesuvius has recognised that valuable process information exists at the metal / machine interface
- Through the acquisition and development of a suite of sensor technologies, Vesuvius is now well positioned to be able to extract this process data at critical areas of the production process
- Vesuvius will work with metals producers to transform this information into useable process recommendations for real time optimization of the metal producers processes



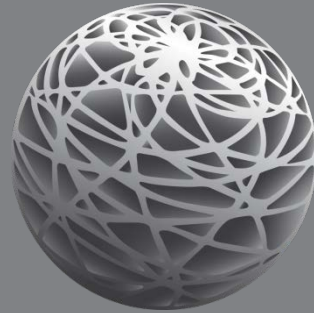

A GLOBAL LEADER IN METAL FLOW ENGINEERING

## Financial Strategy

Chris O'Shea  
Chief Financial Officer

VESUVIUS PLC

# Financial strategy remains consistent...

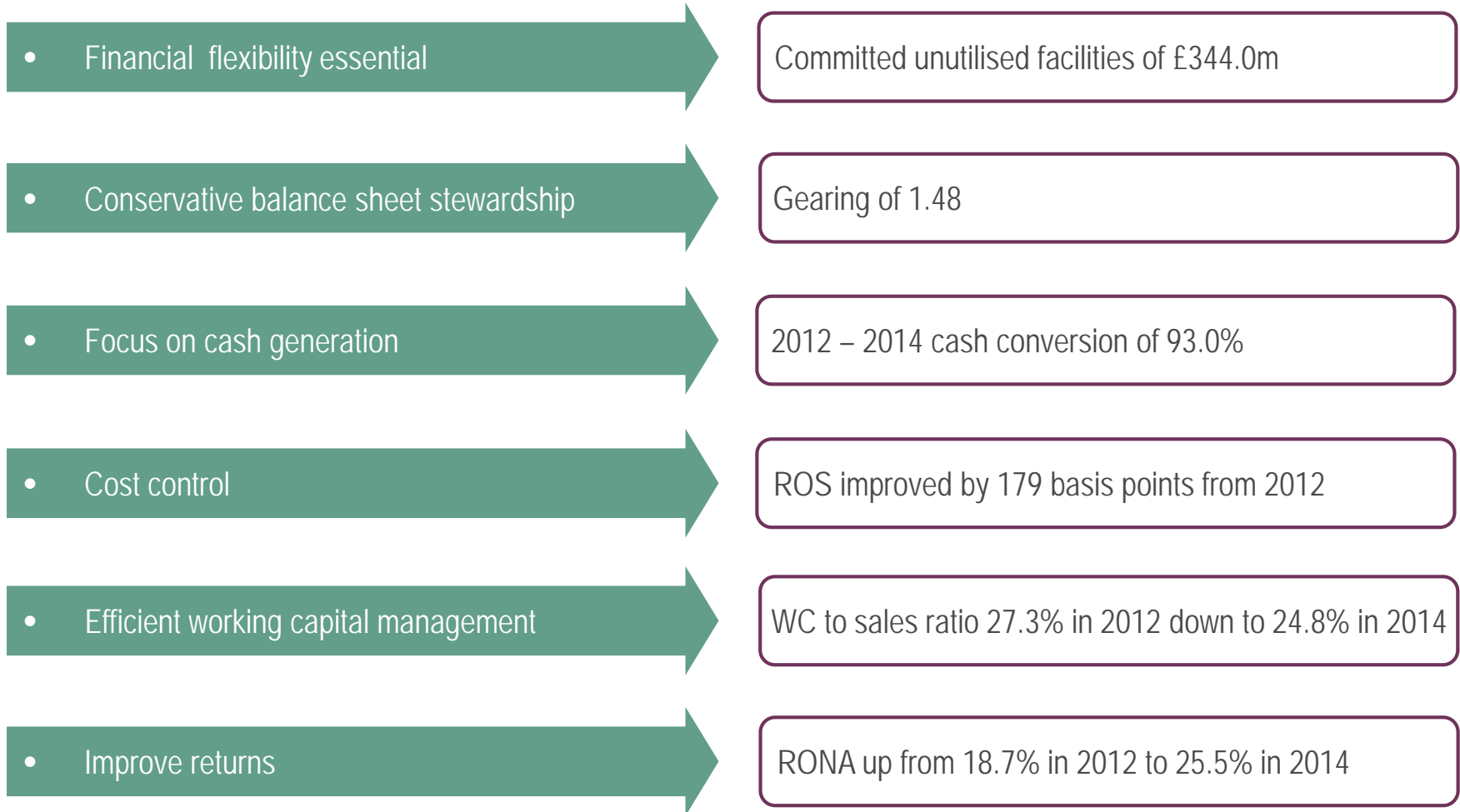

...as evidenced over past 2 years

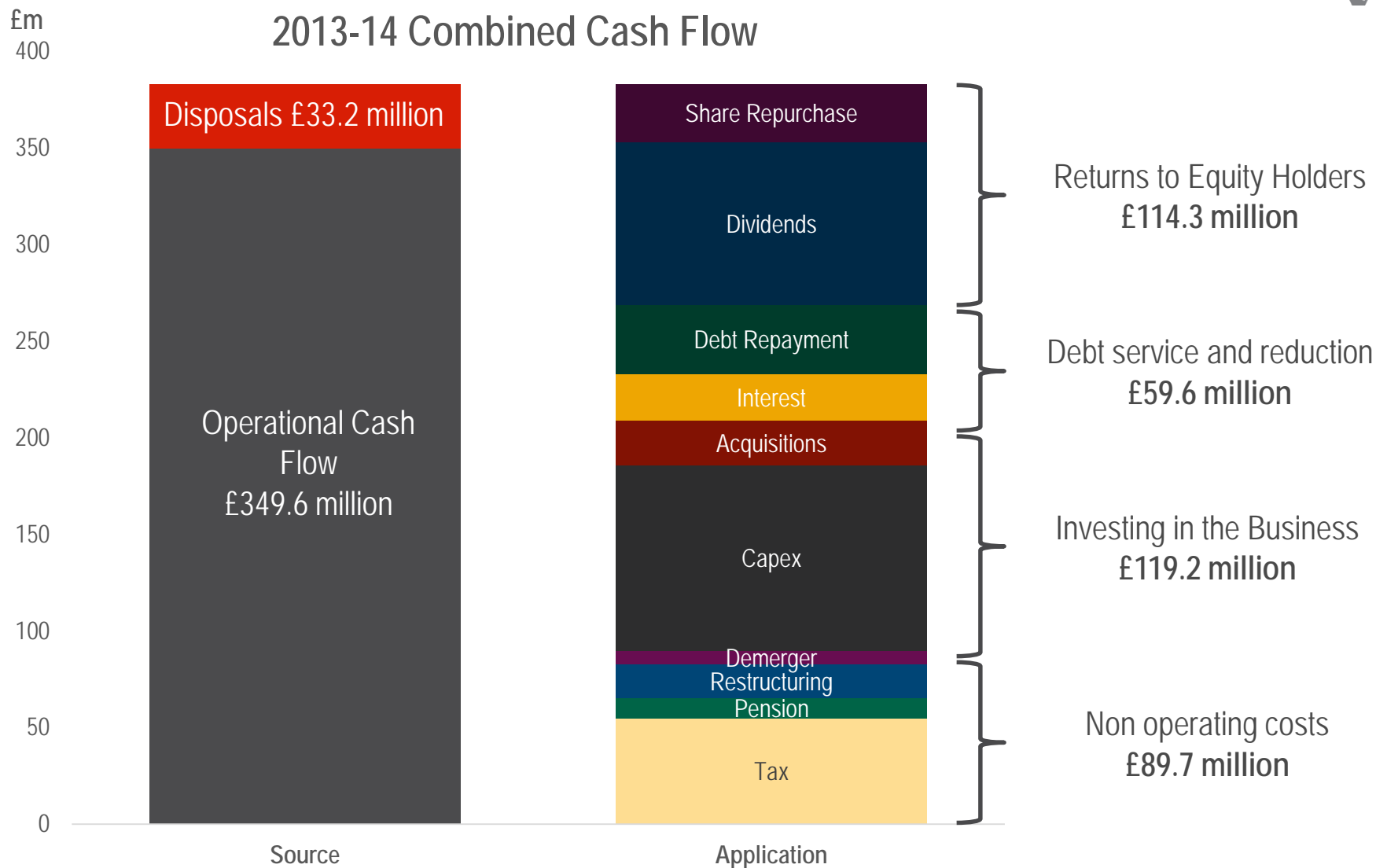

Source:



# Strong balance sheet management will continue...

## Target Capital Structure

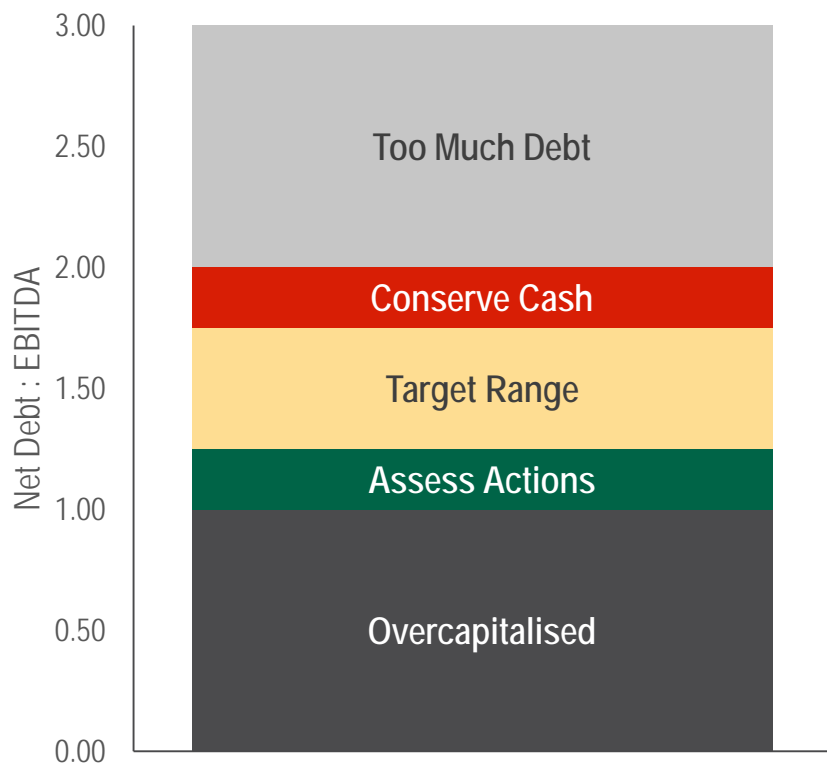

- Governed by 3 times ND:EBITDA ratio
- Internally imposed maximum is 2
  - Retain one turn to guard against short downturns
- Below 1 would trigger consideration of return of capital
- Comfort zone is 1.25 – 1.75



## ...supported by newly placed bank facility

- £300 million multi currency facility
  - Replaces £425 million facility expiring 2016
- 5 + 1 + 1 term
  - 2 x 1 year options at lender's discretion
- £200 million accordion
  - Can be exercised before end of 2016
- Margin cut almost in half
- ND:EBITDA covenant of 3.25

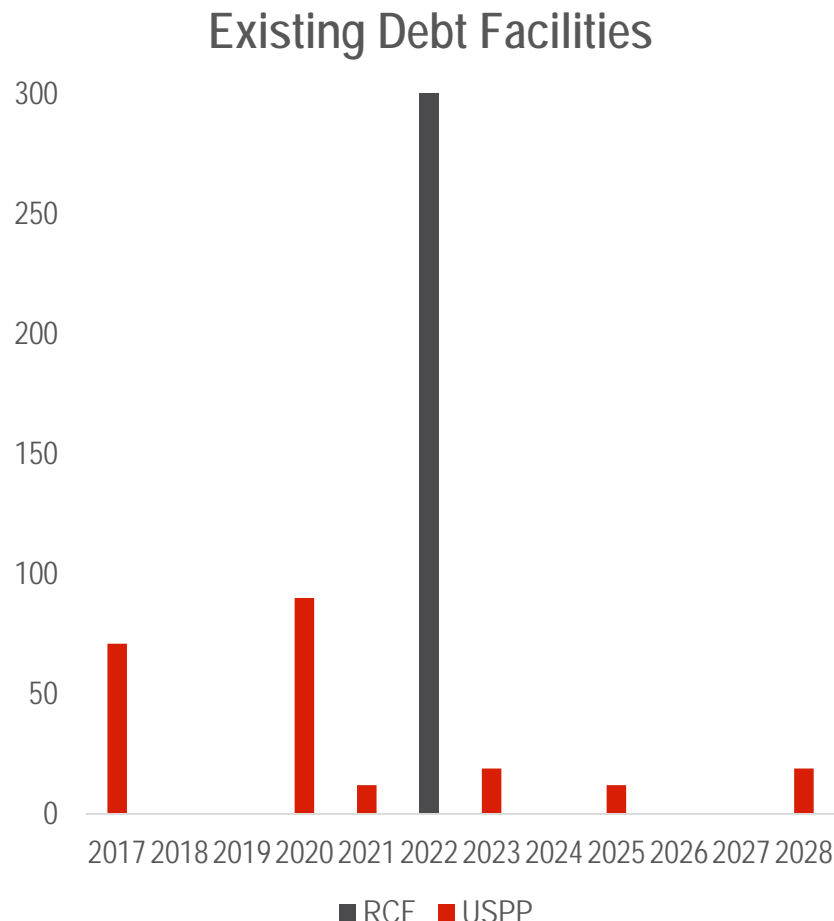

# The organic capital requirements are relatively low...

- Low capital intensity
  - Annual Revenue = c6 x Property, Plant and Equipment
- More working capital reductions to come
  - Inventory reduction programme continues
  - Receivables moving in right direction
  - Supplier financing solutions with new facility

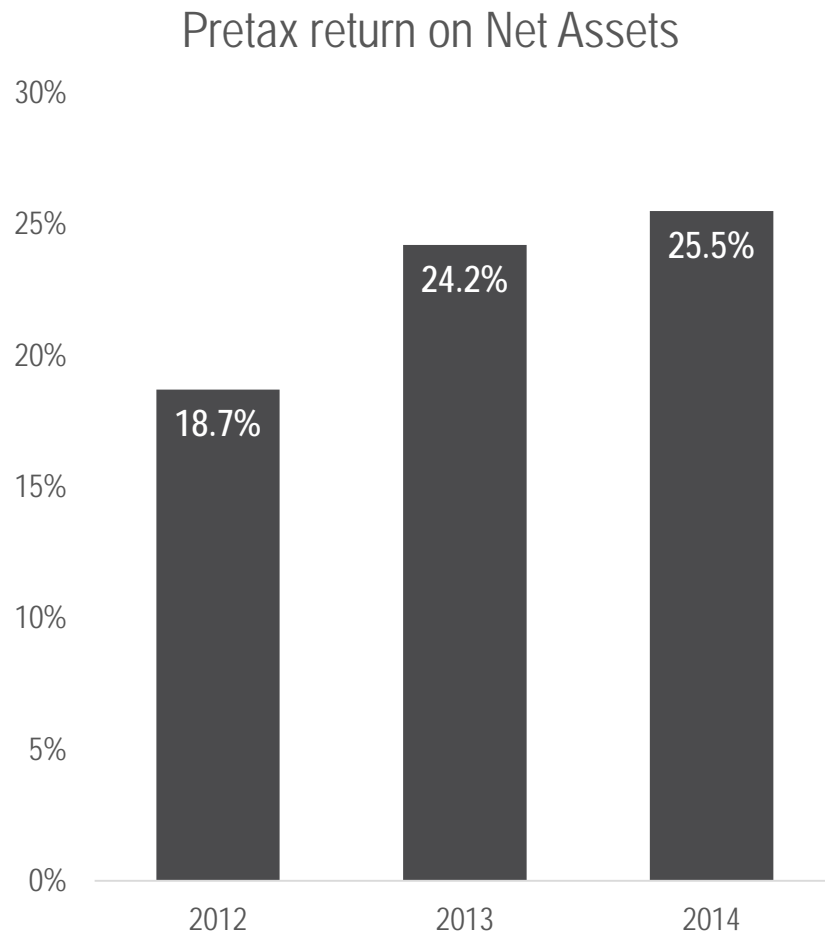

# ...and the M&A strategy is focussed & aligned with strategy

## Core Competence & Strategy

- Clear core competence
  - We are a global leader in **heat containment technology**
- Clear business focus
  - We apply our core competence in a focussed way to supplying **consumable ceramic products** to the **steel and foundry industries**
- Clear strategic Focus
  - Within the steel and foundry industries we are building a business supplying **technical services**

## M&A Priorities

- **Technical Services**
  - SERT / Avemis (2012)
  - ECIL Met Tec (2014)
  - Process Metrix (2014)
  - Sidermes (2015)
- **Steel & Foundry Consumable Ceramic Products**
  - Metallurgica (2012)
- **Heat Containment Technology**
  - Opportunistically based on value



# We anticipate generating substantial free cash flow

Support Organic  
Capex requirements

**Integrated investment framework**

New facilities in growth  
markets (Russia, China,  
India)



Improved R&D facilities  
to drive innovation  
(Pittsburgh, Vizag)

Support M&A  
Strategy

Bolt-on technical  
services  
e.g. Process Metrix,  
ECIL Met Tec, Sidermes

Bolt-on product offerings  
e.g. Metallurgica

Material adjacencies  
when valuations support



Deliver  
Superior Returns  
to Shareholders

Dividend growth in line  
with underlying earnings  
e.g. CAGR of 6.4% from  
2012 – 2014

Return excess capital to  
shareholders  
share buyback post  
PMP disposal

**Increasing productivity and supporting further market penetration through organic capital investment and selective acquisitions at the right price will generate the growth required to increase profits and deliver shareholder value**

# Going forward

- Since 2012 we have delivered on our commitments,
  - streamlining the business
  - improving our margins
  - delivering shareholder value and
  - positioning the company for growth
- We see a significant growth potential for our markets in the mid term
- We are taking the appropriate steps to capture this growth
  - Increased efforts in technology
  - Driving excellence in manufacturing and
  - Developing technical services



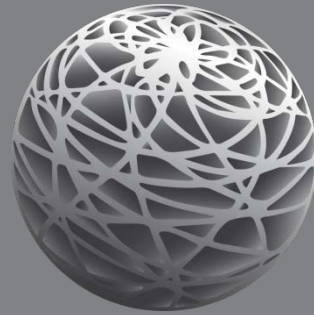

A GLOBAL LEADER IN METAL FLOW ENGINEERING

Q&A

VESUVIUS PLC